

Chopper

GUARANTEED NON-CLOG



Vaughan[®]
Unmatched Reliability



PRODUCT BROCHURE

Wet Well

Vertical Wet Well

- Vaughan's most popular sump pump
- Reliable mechanical seal/oil bath design
- Eliminates suction piping
- Keeps motor and wiring out of the pit
- Lengths to 30' and beyond
- Oil siphon kit and custom deck plate sizes available



Vertical/Submersible Recirculator

- Allows vertical wet well and submersible pumps to be used for mixing and pumpout
- Ideal for scum pits and mixing of floating or settled solids
- Stainless handles as a standard



Electric Submersible

- Popular for sewage lift stations
- Retrofits to most guide rail systems
- Ideal for deep sumps
- Available with rail system or portable
- Triple seal design available
- Upgraded lower seal is standard



Hydraulic Submersible

- Portable pump for tank cleaning
- Lighter weight than other submersibles
- Ideal for mobile equipment



Dry Well

Horizontal

- Various mechanical seal systems available
- Direct or belt drive
- Externally adjustable back pull-out design



Self-Priming

- Direct or belt drive
- Adjustable back pull-out design
- Only self-priming chopper pump in the world
- Replaceable rotating assembly



Pedestal

- Used primarily in dry well applications where floor space is limited
- Various sealing systems available
- Adjustable back pull-out design
- Dry pit submersible option available



CHOPPER CONCEPT



As an innovator, Vaughan is always looking for new ways to change the game. Our patented features brought about revolutionary improvements and set the standard for chopper pumps.

1

Mechanical Cartridge Seal:

Vaughan's unique cartridge style mechanical seal handles the toughest slurries, outperforming standard single-spring seals by reducing problems associated with wrapping or abrasion.

2

Backplate With Internal Cutter:

Stray solids trapped in the mechanical seal area are shredded and removed by the impeller vanes turning against the upper cutter, providing reliable, long-term service.

3

Upper Cutter:

Auxiliary cutters above and below the impeller create a more efficient cutting system for high fiber slurries. The cutters also reduce motor overloads and nuisance tripping. These additional hardened steel patented cutters are one of the critical differences between Vaughan and the competition.

4

Impeller:

Solids are chopped by the cupped and sharpened impeller blades turning across the cutter bar creating a smooth "slicing" effect. The conditioned slurry is easily pumped through the pump and piping system without plugging.

5

Cutter Bar:

Three sets of proprietary cutting features assure positive chopping of all incoming solids.

6

Cutter Nut:

Cuts stringy materials that tend to wrap at the pump inlet.

7

Optional Disintegrator Tool:

Helps break down large debris prior to the pump inlet.

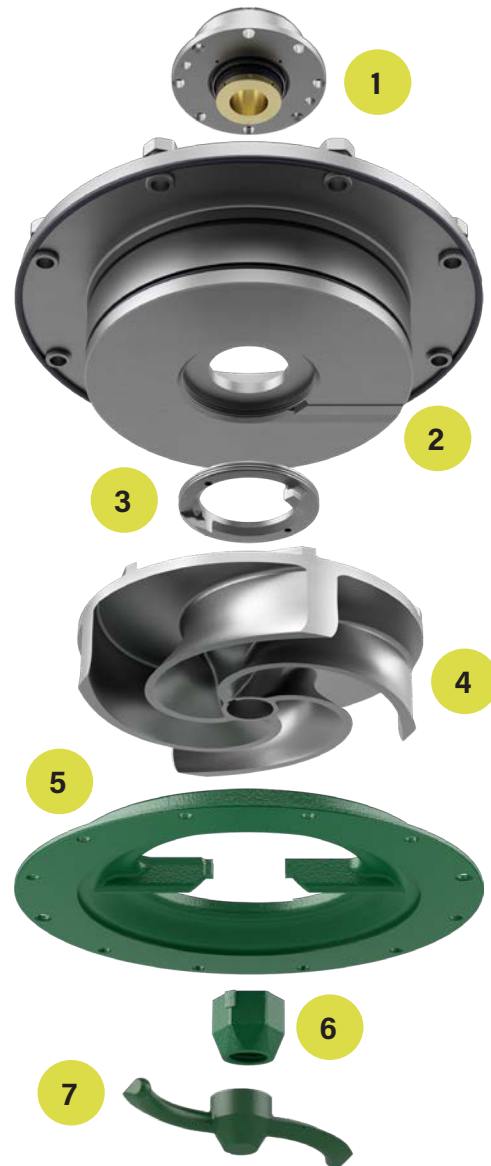

Stainless Steel Models and Parts Available



**SEE MORE ON
CHOPPERPUMPS.COM**

Performance Map - 50 Hz and 60 Hz.

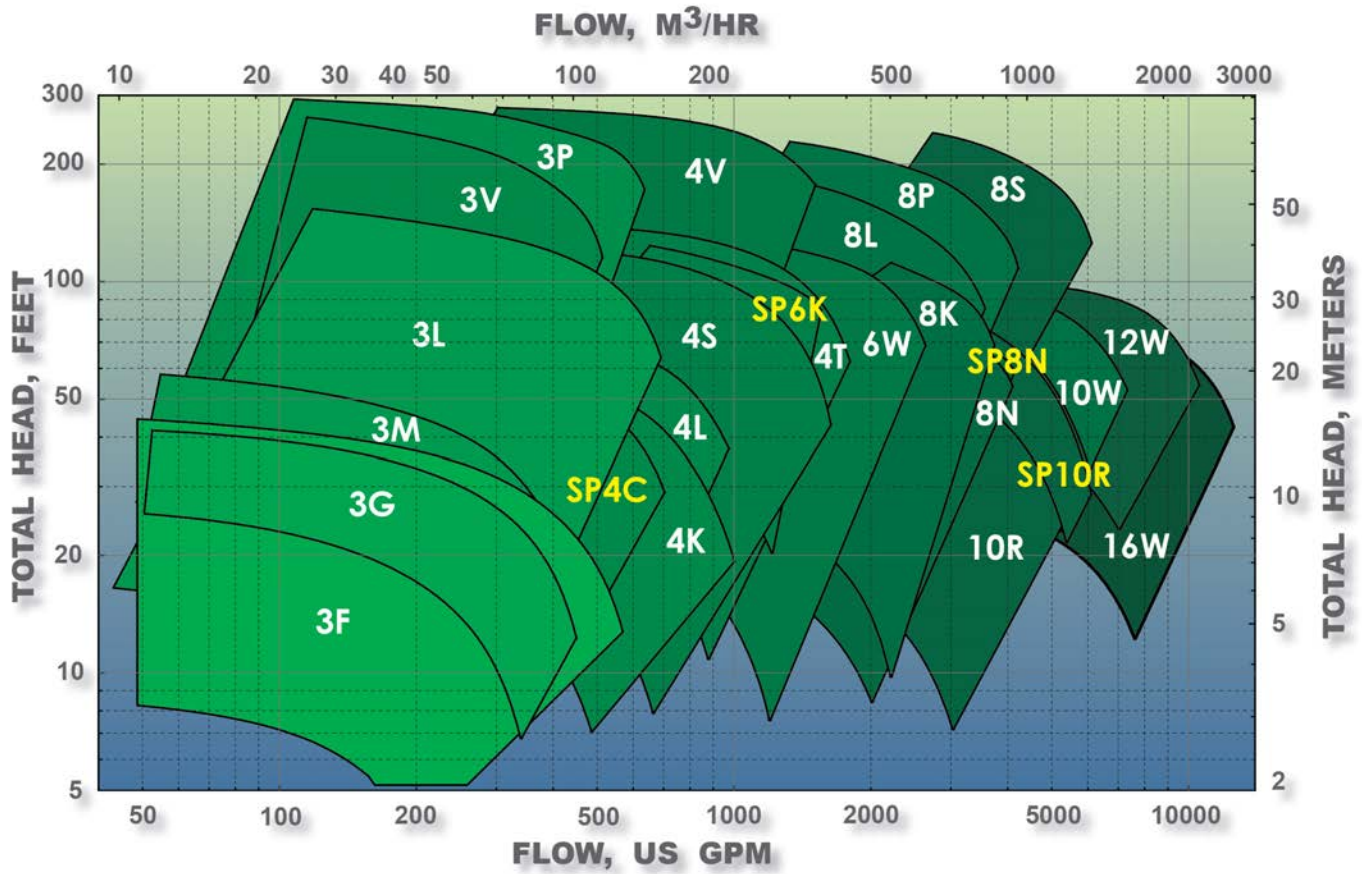

* Yellow text denotes the self-primer pump model

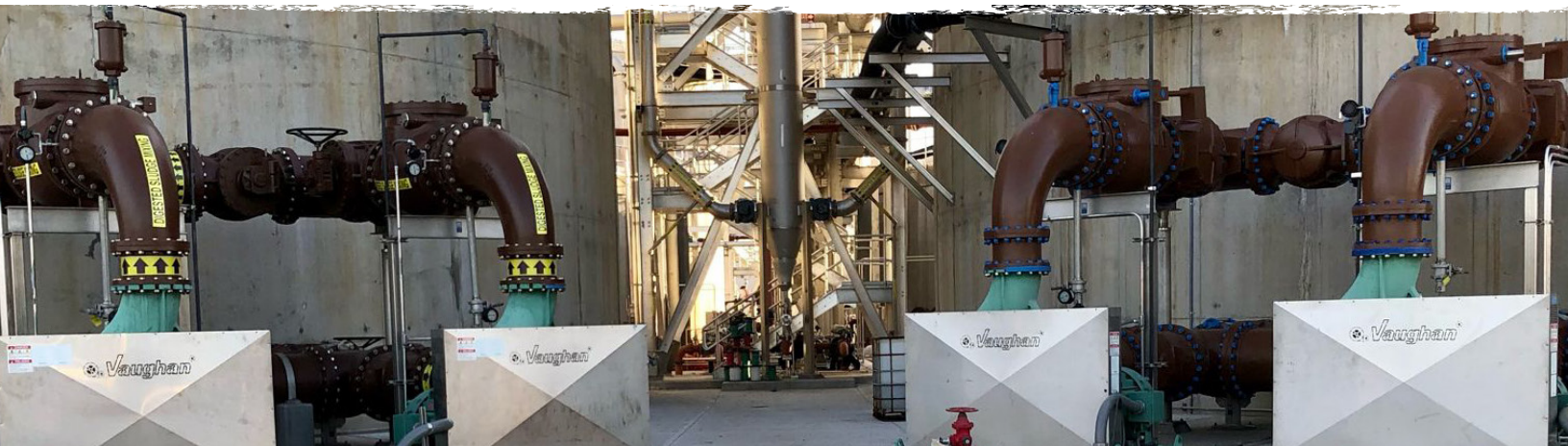

WET WELL PUMPS



Vertical Wet Well

When the going gets tough, turn to the toughest pump on the planet. Since 1960, the unrivaled Vaughan Chopper Pump has been on the cutting edge. This original chopper pump was built first and made to last.

- 1 **Oil-Filled Bearing Housing**
 - Increases bearing life
- 2 **Seal & Bearing Sub-Assembly**
 - Reduces maintenance time
- 3 **Double-Row Thrust Bearings**
 - Absorb all impeller loads
- 4 **Vaughan's Cartridge Style Silicon/Tungsten Carbide Mechanical Seal**
 - Protects bearings and lasts longer
- 5 **Pump-Out Vanes & Upper Cutter**
 - Keeps pumpage away from seal
- 6 **Cast Alloy Steel Impeller, Cutter Bar, Upper Cutter, Optional Disintegrator Tool & Cutter Nut**
 - Case hardened to minimum 60 Rockwell C hardness for wear and impact resistance

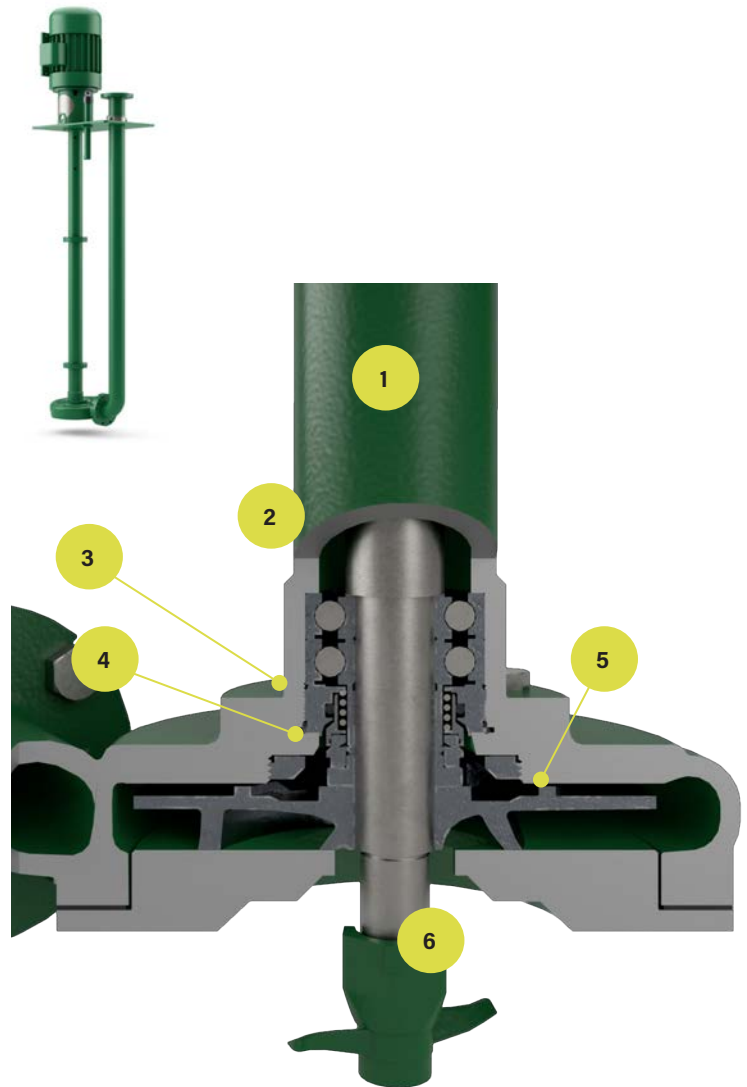

**SEE MORE ON
CHOPPERPUMPS.COM**

Electric Submersible S-Series

Get the power of Vaughan with this heavy duty electric submersible solution. It's available with a rail system or a portable stand, and it can adapt to most guide rail systems.

1 **Explosion-Proof Motor**

- Explosion Proof or Non-Explosion Proof, with moisture sensor and tandem mechanical seals
- 15-minute in-air standard construction
- Also available in Continuous In-Air

2 **Cartridge Seals**

- Vaughan cartridge seal in lower housing

3 **Pump Out Vanes & Upper Cutter**

- Keeps pumpage away from the seal

4 **Oil Level Monitor**

- System constantly monitors oil level in the bearing housing

5 **Cast Alloy Steel Impeller, Cutter Bar, Upper Cutter & Cutter Nut**

- Case hardened to minimum 60 Rockwell C hardness for wear and impact resistance

6 **Oil-Filled Bearing Housing**

- Lubricates bearings and helps protect the submersible motor

7 **Bearing and Seal**

- Bearing and seal above the impeller for the shortest overhang in the submersible pump market
- 100,000 hours of bearing life

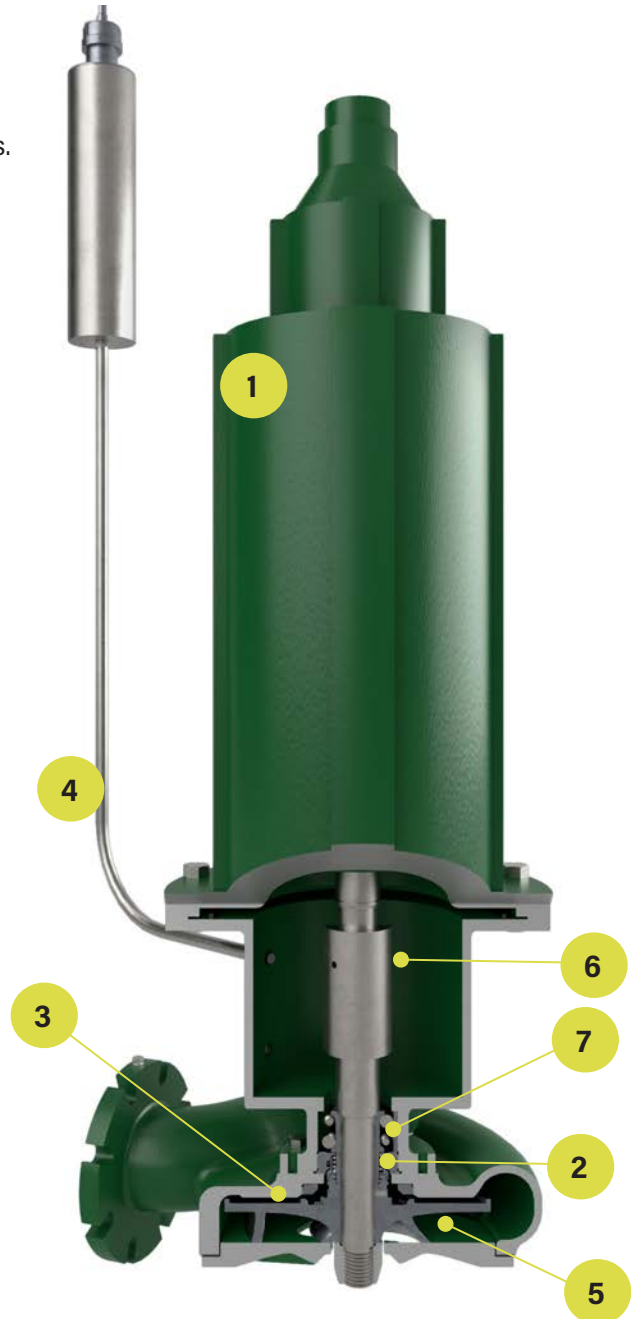

SEE MORE ON
CHOPPERPUMPS.COM

Electric Submersible E-Series

For a solution that's popular with sewage lift stations, choose this traditional, submersible design. It can be easily retrofitted to most guide rail systems.

1

Explosion-Proof Motor

- Explosion Proof or Non-Explosion Proof, with moisture sensor and tandem mechanical seals
- 15-minute in-air standard construction
- Also available in Continuous In-Air

2

Tandem Mechanical Seals

- Includes lower tungsten carbide mechanical seal for maximum motor protection

3

Pump Out Vanes & Upper Cutter

- Keeps pumpage away from the seal

4

Ductile Iron Back Pull-Out Casing

- Provides adjustable impeller-to-cutter bar clearance extending parts life

5

Cast Alloy Steel Impeller, Cutter Bar, Upper Cutter & Cutter Nut

- Case hardened to minimum 60 Rockwell C hardness for wear and impact resistance

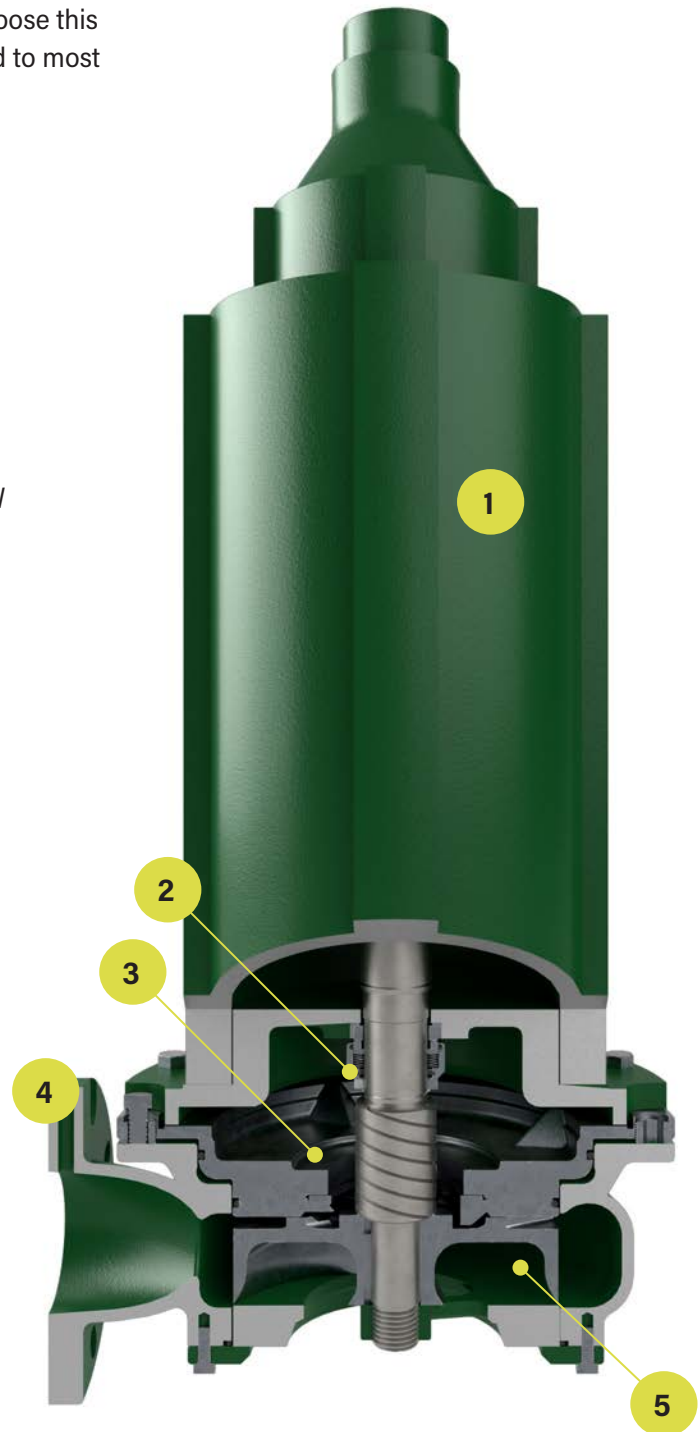

THE MIXING EXPERTS!



From day one, Vaughan Company has not only been a leader in chopper pumps but pit mixing as well. Shortly after patenting his chopper pump design, Jim Vaughan patented a pit mixer because he understood a very simple principle: To get all solids out of a pit you need to homogenize the contents before pumping out. Since 1960, Vaughan has continued to refine this simple principle by producing our various recirculator and conditioning pump product lines. As the mixing experts, we welcome you to bring all your mixing challenges!

Vertical Recirculator Submersible Recirculator

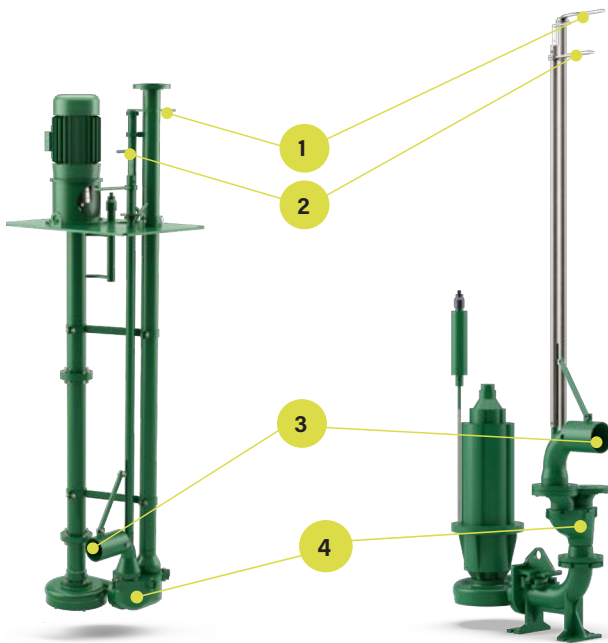

- 1 Valve Operator**
 - Allows ease of valve control, manual or automated
 - 2 Nozzle Handle**
 - Adjusts nozzle direction horizontally and vertically
 - 3 Mixing Nozzle**
 - Hydraulically mixes liquids & solids
 - 4 Ductile Iron Valve**
 - Allows recirculation or discharge
- * Recirculation Valve also available with Horizontal and Self-priming Configurations



MORE ON VAUGHAN RECIRCULATORS

Vaughan Conditioning Pump

Improve the operation of your lift station by using the Vaughan Conditioning Pump. This specific unit is a Vaughan Submersible Chopper Pump mounted on a portable stand and fitted with a high-velocity mixing nozzle. The Conditioning Pump recirculates the contents of the wet well, chopping and mixing to produce a homogeneous mixture that is more easily pumped out by the existing duty pumps.

Floating mats are removed and solids that have accumulated on the floor are re-suspended. As the pump is mounted on a portable stand, it can easily be used in multiple applications at a single job-site, facility or municipality.



MORE ON VAUGHAN CONDITIONING PUMPS

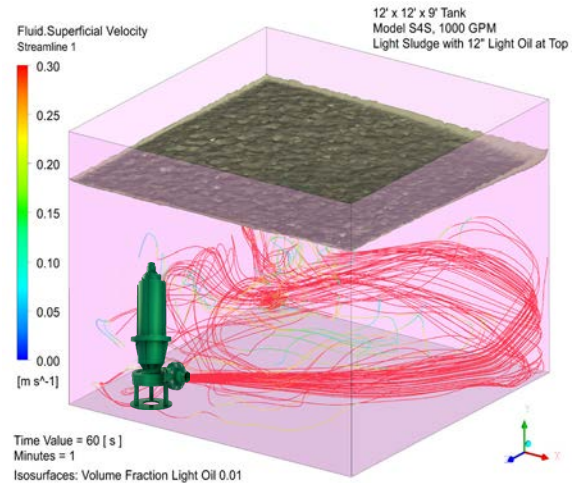

Horizontal E-Series

With this innovative, flushless design, there's no need for flush water. The combined bearing frame design along with the heavy-duty cartridge mechanical seal ensure dependability. External clearances make cutter adjustments easy.

1

Flushless Vaughan Cartridge Mechanical Seal

- Heavy duty design provides reliable long-term operation without the need for flush water
- Available option for flushed tandem seal

2

Eliminates Stuffing Box

- No stuffing box means less chance of solids collecting in seal area

3

Adjustable Back Pull-Out Casing

- Allows external adjustment of both impeller-to-cutterbar and impeller-to-upper cutter clearances without disconnection from piping

4

Oil-Filled Bearing Housing

- Keeps bearings and seal cool and running smooth

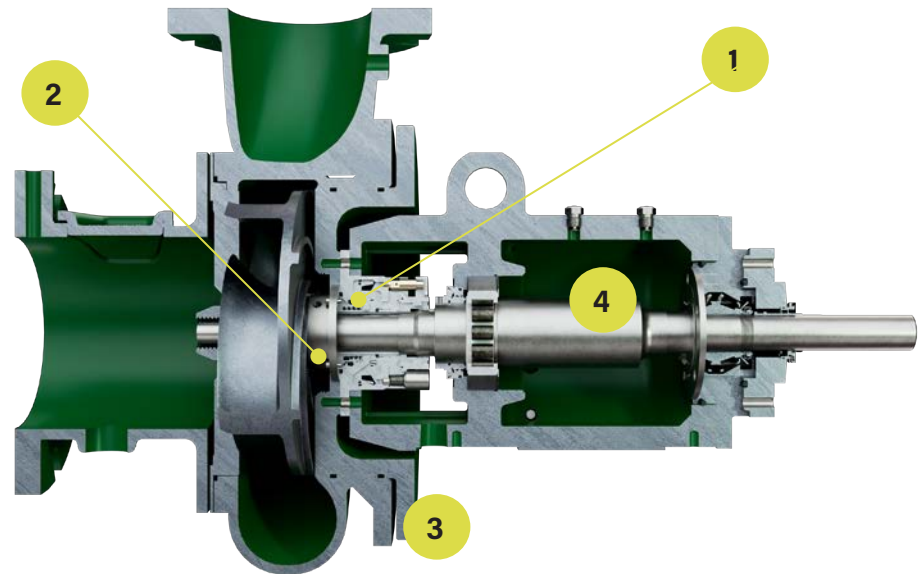

SEE MORE ON
CHOPPERPUMPS.COM

Pedestal E-Series

Get the same deep sump pump benefits of our E-Series, with a flushless design. You can always count on the heavy-duty cartridge mechanical seal. Flushed seals are available if needed. Externally adjusted cutter clearances add ease of use.

- 1 C-Flanged Motor Mount**
 - Piloted for self-alignment
- 2 Oil-Filled Bearing Housing**
 - Keeps bearings and seal cool and running smooth
- 3 Flushless Vaughan Cartridge Mechanical Seal**
 - Heavy duty design provides reliable long-term operation without the need for flush water
- 4 Back Pull-Out Casing**
 - Allows external adjustment of BOTH impeller-to-cutter bar and impeller-to-upper cutter clearances without disconnection from piping
- 5 Pump Out Vanes & Upper Cutter**
 - Keeps pumpage away from the seal
- 6 Cast Alloy Steel Impeller, Cutter Bar, Upper Cutter & Cutter Nut**
 - Case hardened to minimum 60 Rockwell C hardness for wear and impact resistance
- 7 Custom Pedestals**
 - Can reduce or eliminate piping modifications for retrofits (available upon request)

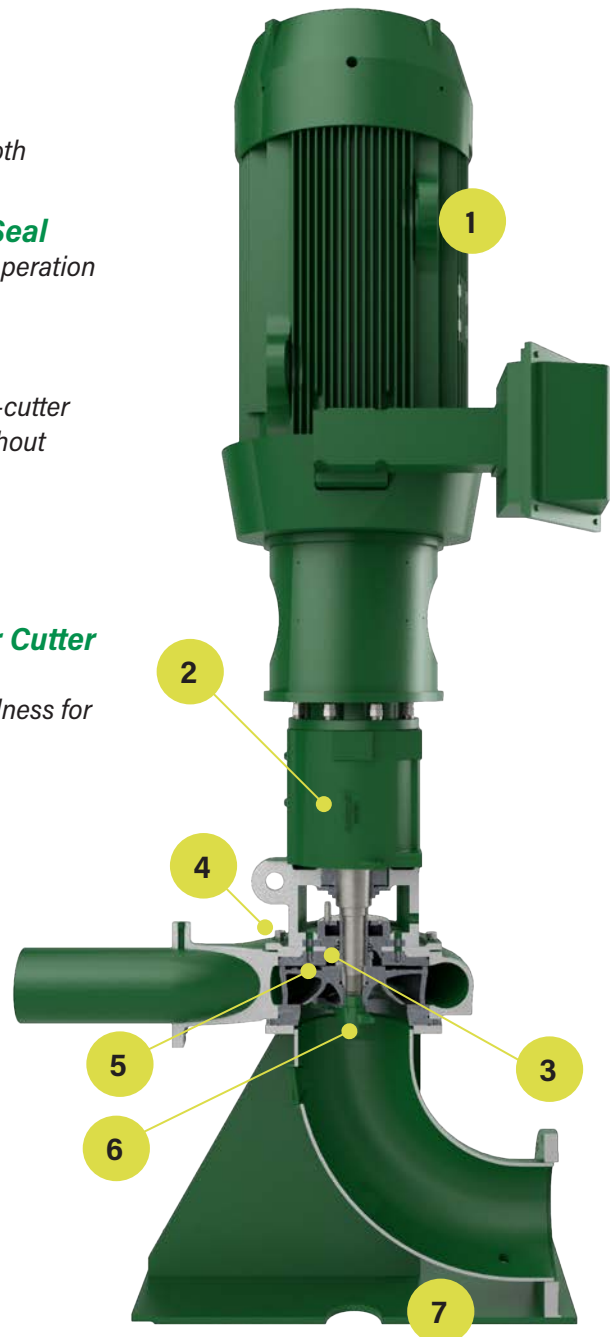

SELF-PRIMING PUMP



Self-Primer Chopper Pump

Turn to the only self-priming chopper pump in the world. This cutting-edge solution provides self-priming up to 24' of re-prime lift. The heavy-duty cartridge seal is rock solid, with discharge from 4" to 10". It's available in direct or belt drive, and provides 100 to 5000+ GPM. The rotating assembly can be removed for quick replacement or easy maintenance.

- 1 **Heat Treated Alloy Steel Chopper Impeller, Cutter Bar & Upper Cutter**
 - Handles all incoming solids without clogging
- 2 **Ductile Iron Housing, Casing & Bearing Housing**
 - Increases durability
- 3 **Vaughan's Cartridge Style Silicon/Tungsten Carbide Mechanical Seal**
 - Isolates pumpage from bearings and motor
- 4 **Thrust Bearings**
 - Absorb all loads
- 5 **Oil Lubrication**
 - Keeps bearings and seal cool and running smooth
- 6 **Adjustable Casing & Rotating Assembly**
 - Rotating assembly removable for ease of maintenance
- 7 **Casing Heater (Optional)**
 - Available for cold weather environments

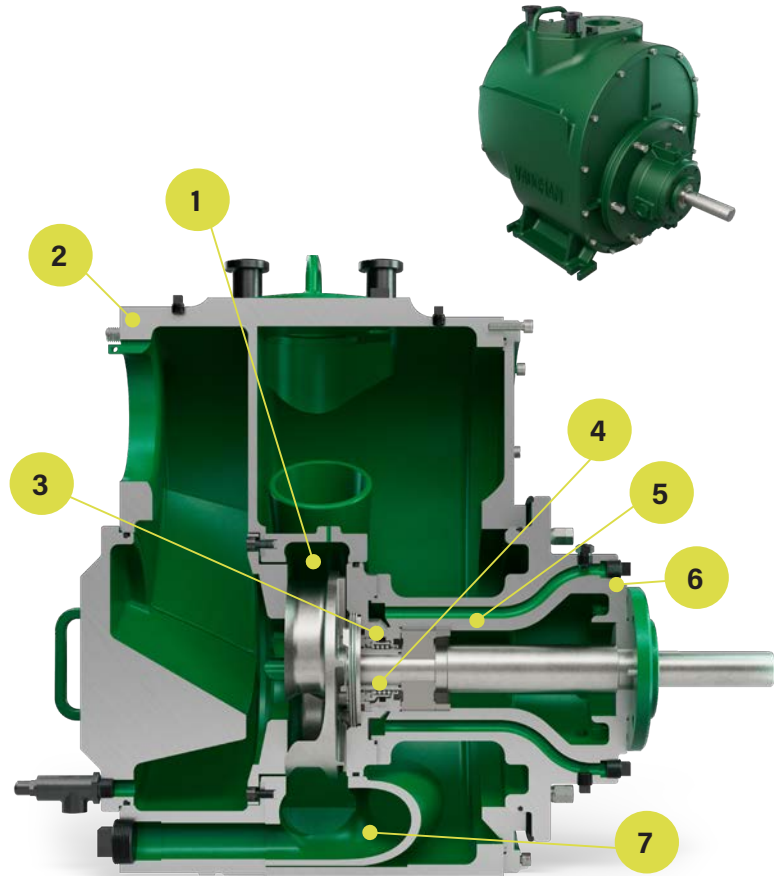

Tandem Flush Mechanical Seal

- Rugged design for Vaughan Chopper Pumps
- Simple and easy field installation
- Application-specific face materials and elastomers
- Available in all sizes of Vaughan horizontal and pedestal dry pit pumps
- Optional Items:
 - Low-cost flow regulator to control flow
 - And/or thermal valve for low water usage

3-Way Valve

- Available in 4", 6", 8", and 10" sizes as a stand-alone valve or as part of a Vaughan System
- Valve is a non-plug design using a rotatable stainless valve disk to allow discharge out of either of the top two ports
- Switch or split flow between the two ports
- Valve disc may be manually or electronically operated with an actuator

Auto Valve Actuator

- For Vaughan recirculating chopper pumps and 3-way diverter valves
 - Allows for complete automatic operation of the recirculation valve on Vaughan vertical wet well submersible recirculator chopper pumps
- Features Include:
- Weatherproof stainless steel enclosure
 - 110 volt motor operator
 - Ball screw drive with worm gear reducer
 - Hardened steel worm gears
 - Aluminum housing and cover tube
 - Class 1 Group D Explosion-Proof Actuator also available

Disintegrator Tools

- Single, double, and triple disintegrator tools
- Integrated with the cutter nut or as a stand-alone option
- Ideal for non-stringy solids that obstruct the suction inlet
- Options include
 - Standard hardened steel
 - Stainless steel
 - Serrated

4 Segment Cutter Bar

- Cutter Bar with additional cutting fingers to increase cut points
- Pre-conditions and breaks down solids into smaller particle sizes
- Available for specialized and/or custom applications

Quick Disconnect

- Alternative install method for discharge piping on vertical wet well models
- Keeps discharge piping below ground or deck plate to prevent freezing
- Easier installation and removal of pumps in cold weather environments

Oil Siphon Kit

- Kit available for vertical wet wells
- Siphon oil and replace easily without removing the pump





Food Processing

- Blood
- Carrots
- Chickens
- Corn Husks
- Ears, Hair, Hooves, Horns
- Fat
- Feathers
- Fish
- Fleshings
- Hide Pieces
- Potatoes
- Turkeys
- Tomatoes



Paper & Wood Products

- Broke Pits
- Carbonized Bark
- Chip Conveyors
- Clarifier Scum
- Coal Pile Runoff
- Conveyor Gallery Sumps
- Drainage Sumps
- Fly Ash
- Knot and Bark Handling
- Log Soaking Vats
- Lime Sludge Transfer
- Underflow to Dewatering
- Woodyard Sumps



Automotive / Steel

- Boiler Blowdown
- Chrome Plating Slurries
- Coke Breeze
- Coke Tar Decanter Sludge
- Glass and Plastic
- Iron Ore Pellets
- Metal Machine Chips
- Mill Scale
- Oil Washdown
- Paint Overspray Sludge
- Roll Grinder Coolant (Swarf)
- Quench Pit



Chemical / Petrochemical

- API Separators
- Coke Slurries
- Detergent Cakes
- Latex Skins
- Lead Oxide Slurries
- Oil Waste
- Plastics
- Pumice Hand Cleaner
- Refinery Mud
- Storm Drains
- Sulfur Froth
- Recycling



Commercial Laundry Wastewater

- Clothes
- Linens
- Rugs
- Uniforms
- Floor Mats



Facility Wastewater Management

- Casino
- Hospital
- Resort/Hotel
- Amusement Parks
- Airport
- Mall
- Race Track
- Jail/Prison



**VAUGHAN
APPLICATIONS**



Typical Municipal Flow Diagram



CSO
Screenings

Sludge
Transfer



Primary
Clarifier Scum

Digester
Mixing

- 1 Raw Sewage**
Used in lift stations, CSO facilities, headworks, prisons, hospitals, restaurants
- 2 Screenings / Septage**
Easily chops raw concentrated solids, including rags, plastics and hair
- 3 Clarifier Scum Pits**
Transfers or conditions primary & secondary scum without plugging or air binding
- 4 Sludge Transfer**
Eliminates "roping" and clogging in clarifier underflow to thickener
- 5/6 WAS / RAS**
Continuously conditions return and waste activated sludges
- 7 Thickened Sludge**
Handles high sludge consistencies
- 8 FOG (Fats, Oils, and Grease)**
Uses organic waste to enhance methane production
- 9 Digester Recirculation**
Eliminates heat exchanger clogging while conditioning sludge
- 10 Tank Mixing**
System conditions and mixes in a dual-zone rotational flow pattern
- 11 Digested Sludge Transfer**
Handles high sludge consistencies



**SEE MORE ON
CHOPPERPUMPS.COM**

TYPICAL MUNICIPAL FLOW DIAGRAM

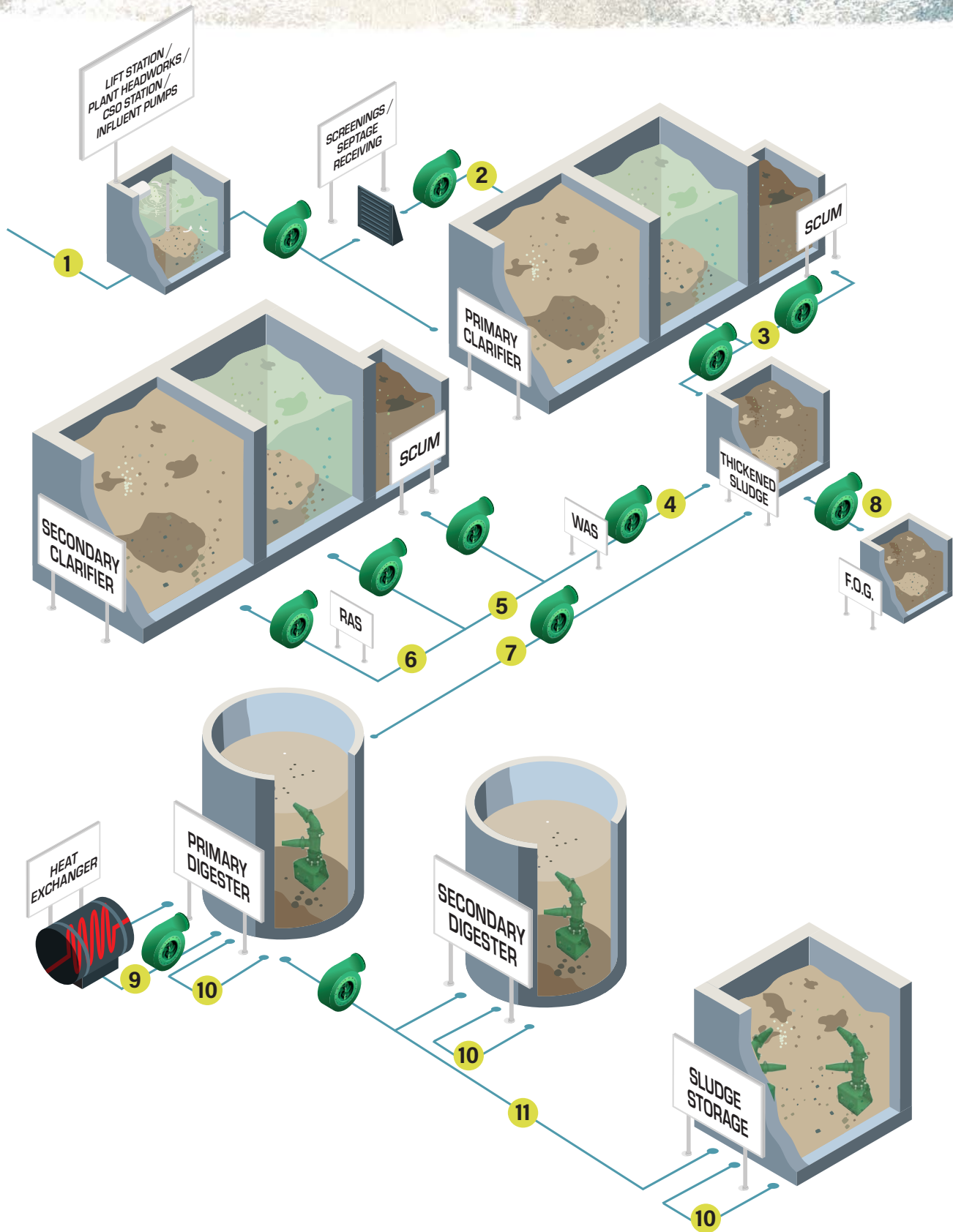



Vaughan®

Unmatched Reliability

364 Monte Elma Road, Montesano, WA 98563 USA
Phone: (360)249-4042 • FAX: (360)249-6155 • US Toll Free: (888)249-2467

In the late 1950s, Jim Vaughan saw a need to help local Washington state farmers resolve clogged manure pumps. A true innovator at heart, Jim pushed beyond expectations to help his neighbors by inventing the world's first chopper pump. Now, since 1960, Vaughan Company remains committed to giving customers outstanding service and the most dependable product solutions in the world.

To maintain our position as the industry leader, Vaughan Company consistently asks the same question as our founder: "What could make this better?" Using innovative technology like our in-house, 3D computer modeling, we create exacting fits and precision castings for all components. We also meet with customers on a consistent basis to understand and resolve the latest issues in water management. The more we ask and innovate, the better we solve the challenges facing engineers and technicians across the globe.

While we have sales and support available worldwide, Vaughan Company remains "Made in America." All of our products are manufactured in the U.S., in our 140,000 sq. ft. Washington state manufacturing facility. We encourage both potential and current customers to reach out to us for details on eligibility for federal aid programs as well as to arrange plant tours.

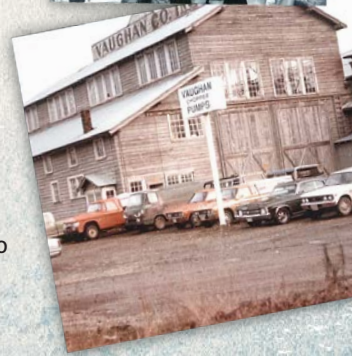

Learn more about each of our products at ChopperPumps.com

VAUGHAN® Chopper Pumps

Wet Wells, Dry Wells, Submersibles, Self-Primers, Recirculators



ROTAMIX® Process Mixing System

Tank and Digester Mixing



TRITON® Screw Centrifugal Pumps

Wet Wells, Dry Wells, Submersibles



Also Available

Floating Pumps, Mixers, Auger Choppers,
Vortex Choppers, Produce Disposal Choppers



**GET STARTED ON
YOUR PROJECT AT
CHOPPERPUMPS.COM**

Vaughan®, Triton®, Rotamix® and Scumbuster® are registered trademarks of Vaughan Co., Inc.

© 2024 Vaughan Company. All Rights Reserved. BRCH-CHPR (07024)