

# ROTARY PISTON PUMP

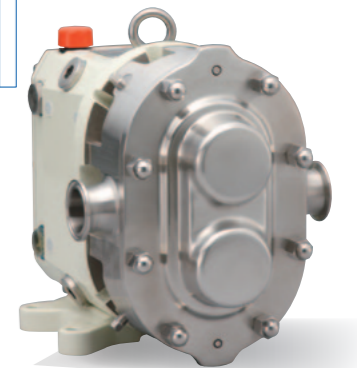
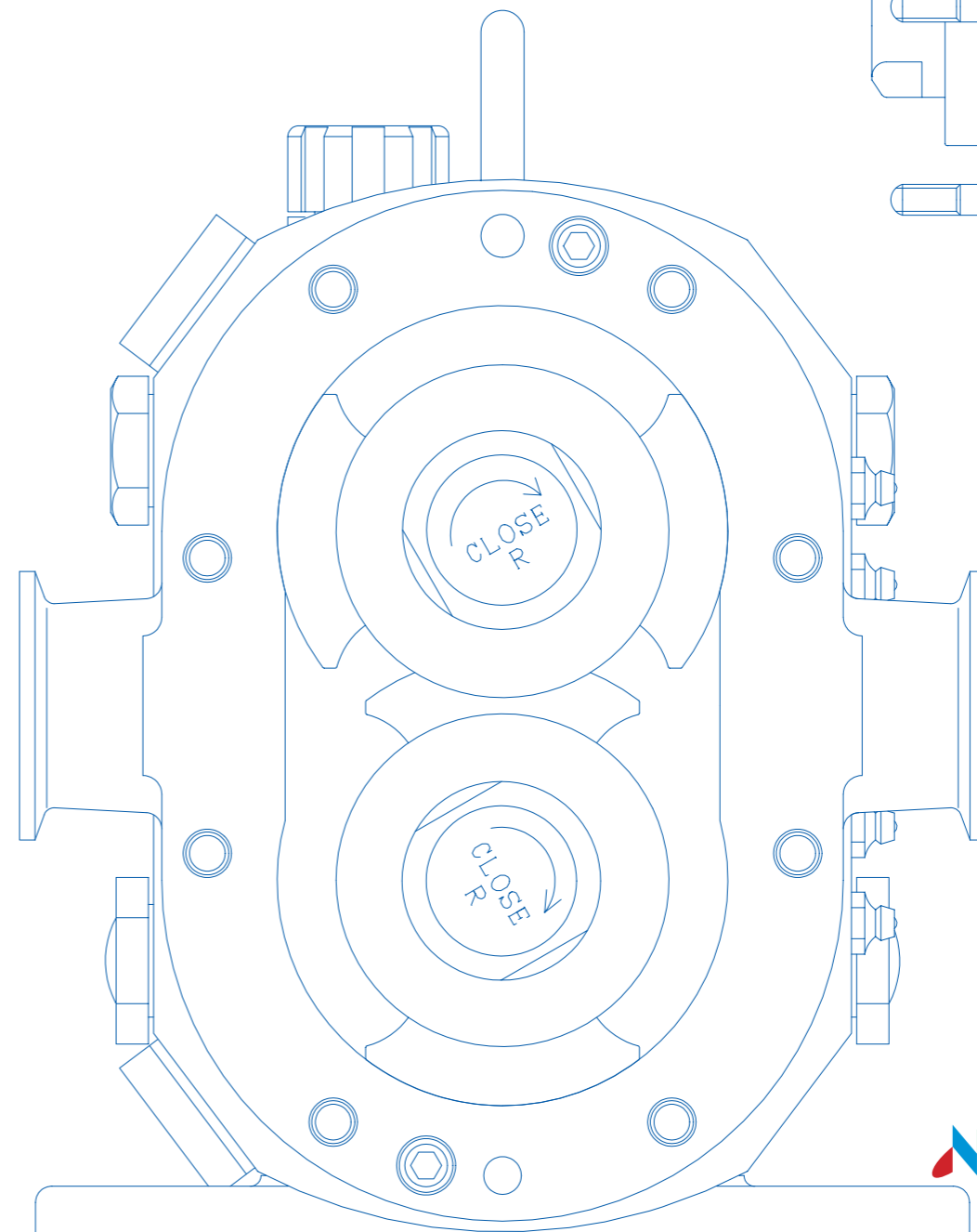
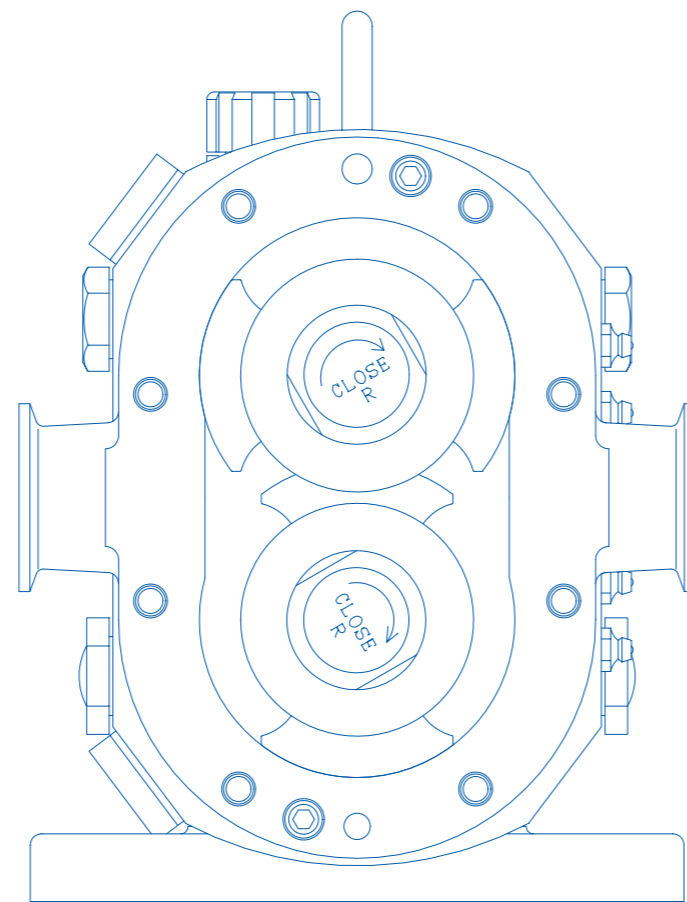

Manufacture:  
**NAKAKIN CO.,LTD.**  
**PUMP DIVISION**

2-10-5 Kasuga Kitamachi Hirakata Osaka  
573-0137 Japan  
E-mail:pumpinfo@nakakin.co.jp  
www.nakakinpump.jp/e

 **NAKAKIN**



# No.1 in Japan — One-Step Production. Nakakin expands to Europe, North America and world-wide!!

Since its founding in 1950, based on its die and casting technologies, Nakakin has worked actively in the automotive industry with firms such as Toyota and Mitsubishi Motors and so on. Nakakin supplies cast engine parts and develops and produces metal dies. Nakakin's technologies also produce quality pumps. Our unique one-step production ensures quality processing from primary raw-material cast products and parts production to pump assembly, performance testing, and direct shipping from our own factories. Valuing the suggestions and support of over 20,000 customers, Nakakin now accounts for Japan's largest rotary piston pump market share. Several hundreds of rotary piston pumps are sold in Germany and other European nations each year. Nakakin provides reliable quality products and services to customers in Europe, North America and world-wide.



## CONTENTS

Introduction	01
Special Features	03
Series	05
Industries	07
Product Lineup	09
<b>JM/JO</b>	
Features	11
Structural Drawing	13
Codification Chart	14
Performance Curve	15
Dimensional Drawing	21
<b>JMU</b>	
Features	23
Structural Drawing	25
Codification Chart	26
Performance Curve	27
Dimensional Drawing	30
<b>SC</b>	
Features	31
Structural Drawing	33
Codification Chart	34
Performance Curve	35
Dimensional Drawing	36
<b>AMXN</b>	
Features	37
Structural Drawing	39
Codification Chart	40
Performance Curve	41
Dimensional Drawing	42
One-Step Production/Principle of Operation	43
CIP/Vented	44
Company Profile	45
Technical Information	46

JM/JO

JMU

SC

AMXN



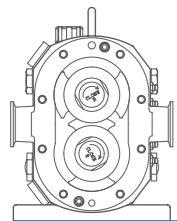

# Special Features

## What makes Nakakin pumps special?



**With built in safety mechanism, Nakakin pumps offer excellent discharge capacity, suction and consistent volume flow not found in non-contact structure pumps.**

Nakakin covers all phases of product design, development, manufacture, and maintenance, done to produce high-quality high-performance pumps clearly incorporating customer needs. Certified by 3-A and European Hygiene Engineering and Design (EHEDG) and ensuring safety by performance-testing all pumps, Nakakin enjoys very high customer satisfaction.

### Nakamura Metal No. 3

Years of carefully cultured technology have enabled Nakakin to develop a unique proprietary alloy — Nakamura Metal No.3. An original patented stainless-steel, Nakamura Metal No. 3 has less thermal expansion, achieving 70- $\mu$  clearance between the rotor and casing — the smallest in the industry. This minimum clearance contributes to high-performance discharge capacity, suction, and quantitative consistency unmatched by any competitor.

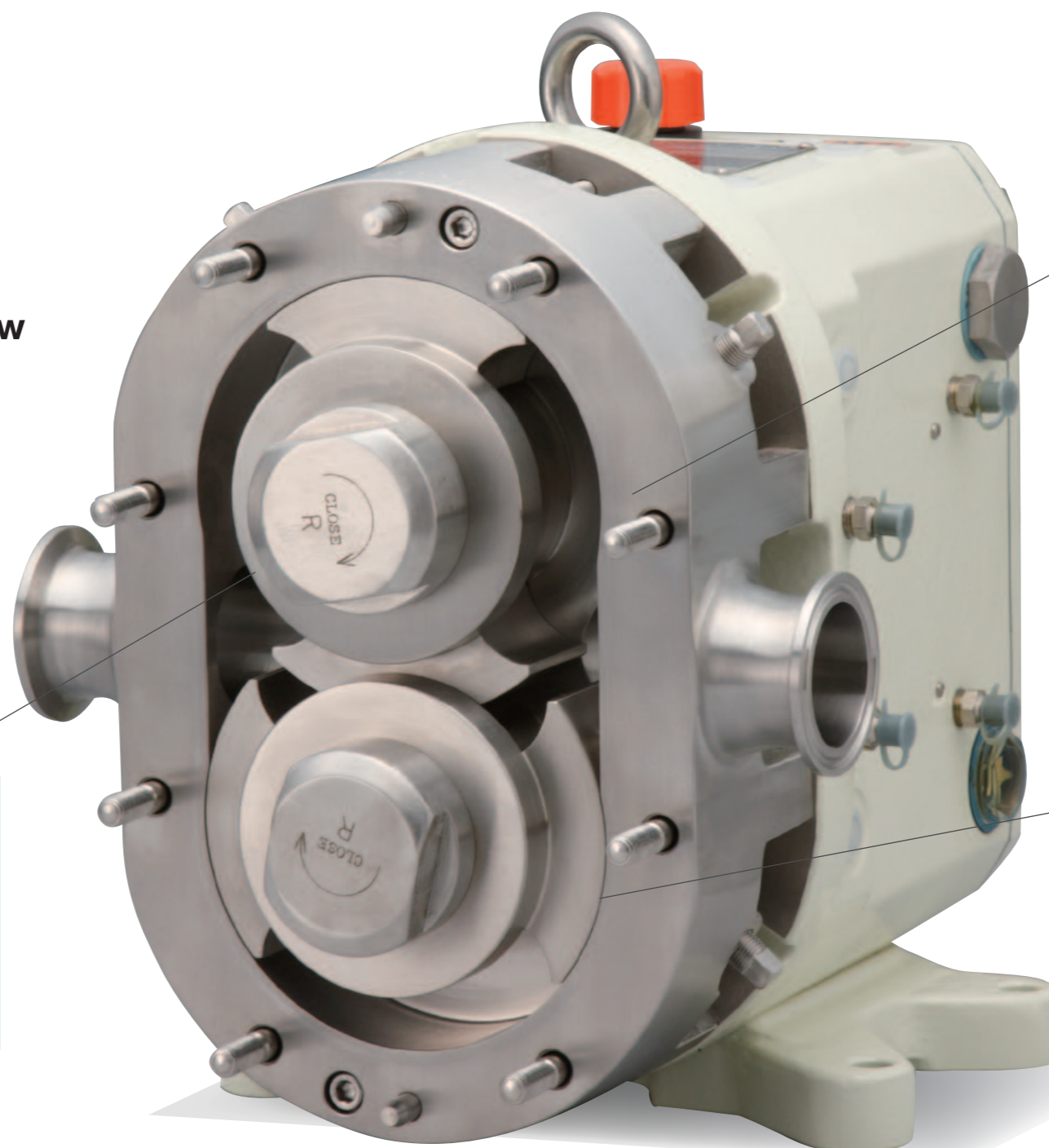

### Raw Material

In our foundry, Nakakin manufactures the major pump parts coming into contact with liquids — a practice only Nakakin provides. Nakakin's production starts with excellent engineers and artisans melting and pouring metal into molds to make raw parts. Nakakin's high-performance high-quality pumps are the result of Nakakin's corporate policy "Starting at ground level."



### Machining Accuracy and Assembly Precision

Nakakin inspects every single pump for accuracy. Undergoing approximately 100 inspection tests, including adjustment to the precision of one hundredth millimeter (10-micrometers), Nakakin pumps finish up in high-load operation testing to ensure safety. Extremely high machining accuracy and assembly precision helps reduce the number of parts needing adjustment, giving Nakakin pumps a superior, more durable life.



JM/JO

JMU

SC

AMXN



# Series

## JM/JO

These models use inner seals, JM for mechanical sealing and JO for O-ring sealing. Simple structures making dismantling and reassembly easy and providing a long effective life with high performance make these models the most popular.

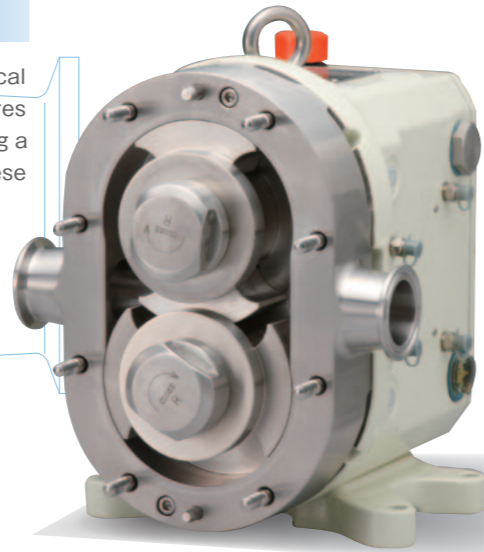
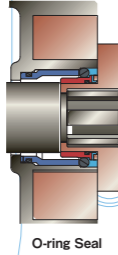
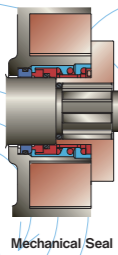

## JMU

These models use outer mechanical sealing. Their simple structure makes dismantling and reassembly easy. Clients can select from single, quench, and tandem mechanisms. Designed to handle a wide variety of liquids, these models work especially well with corrosive and fiber-containing liquids.

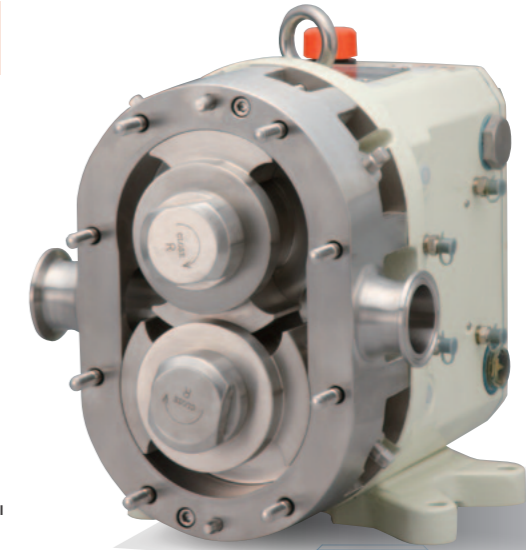
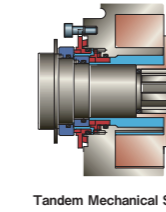
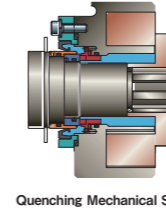
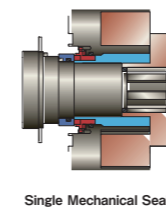

## Supported by high quality and high performance, each of Nakakin's four pump types is unique.

A casting foundry combining Japan's technologies and excellence in Nakakin produces high quality and high performance rotary piston pumps. Our wide range of approaches to sealing includes using inside and outside mechanical seals to meet individual applications. Nakakin pumps are easy to clean, easy

the art of design and production with our own casting foundry. performance rotary piston pumps. and outside mechanical seals to meet individual applications. to dismantle, and easy to reassemble.

## SC

The SC type is specifically designed for cleaning and washing ease. Using a flat cover and eliminating bosses allows these pumps to provide effective washing and cleaning while leaving less liquid residue. The simple structure makes dismantling and reassembly easy.



## AMXN

Designed for completely aseptic liquid distribution, these pumps isolate liquids completely from the atmosphere to ensure aseptic conditions. Distributing mediums such as sterilized water and steam, these models are suited to aseptic production lines of products requiring long-term preservation such as dairy products and medications.

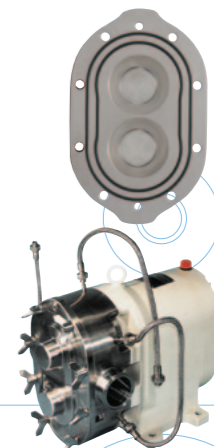
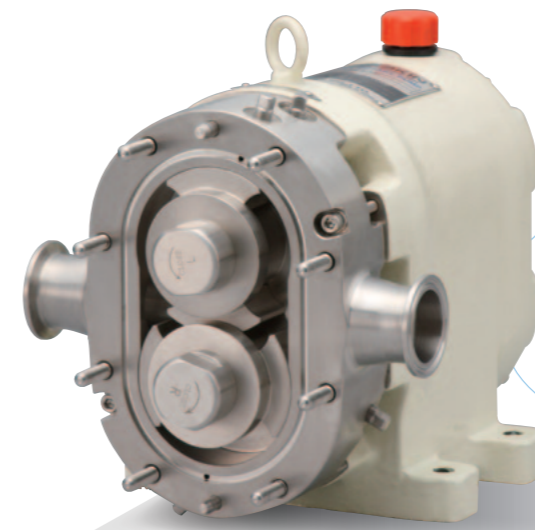

JM/JO  
 JMU  
 SC  
 AMXN



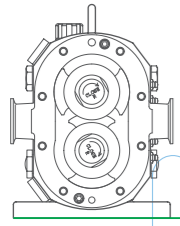

# Industries

Japan's No.1 Rotary Piston Pump  
**NAKAKIN**

## With the motto "Suitable for all liquids", Nakakin leads the world market!!

Heeding customer comments and advice since 1950, Nakakin now has over 20,000 pump-using clients in industries including dairy products, food, beverages, and cosmetics. Due to our outstanding technology, Nakakin has secured an unrivalled market share.



Dairy

- Ice cream
- Cream
- Butter
- Margarine
- Cheese
- Evaporated milk
- Condensed milk
- Yoghurt



Foods

- Tomato paste
- Bread dough
- Ketchup
- Tofu
- Sauce
- Mayonnaise
- Yeast
- Baby food



Confectionery

- Sugar
- Bean paste
- Honey
- Jam
- Molasses
- Marmalade
- Caramel syrup
- Candy



Beverages

- Juice with pulp
- Coffee
- Concentrated juice
- Green tea
- Vegetable extracts
- Sports drinks
- Wine



Cosmetics

- Lotion
- Soap
- Shampoo
- Emulsion
- Conditioner
- Hair dye
- Skin cream
- Toothpaste



Pharmaceuticals

- Artificial blood
- Pure water
- Artificial protein
- Essence
- Liver oil
- Disinfectant
- Vitamin oil
- Bottle

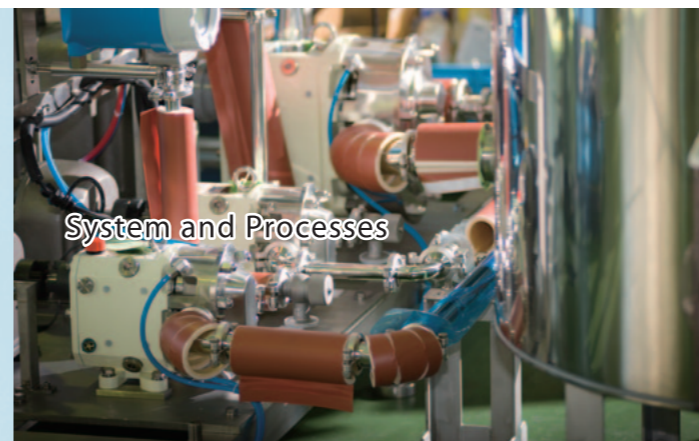

System and Processes

- Crystallisation
- Filling/Emptying
- Emulsifying
- Concentrating
- Homogenising
- Drying
- Metering
- Bottling



Other

- Paint
- Emulsion
- Ink
- Adhesives
- Petroleum
- Detergents
- Glue

JM/WF  
JMU  
SC  
AMXN



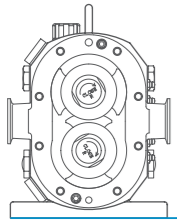

# Product Lineup

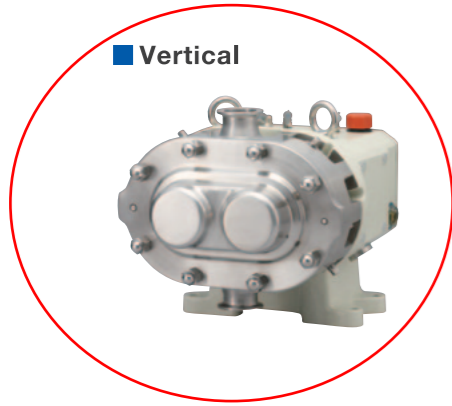

■ Vertical



■ Rectangular Inlet

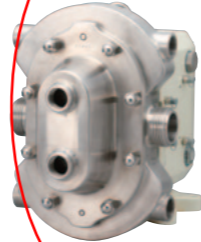

■ Jacket (Casing & Cover)

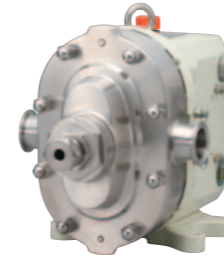

■ Vented Cover



■ 3A



■ EHEDG

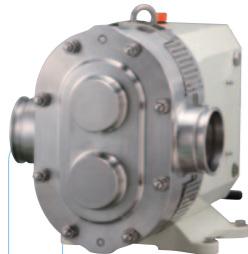

■ Big Pump  
(6s 1470L/min)

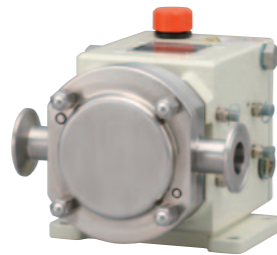

■ Mini Pump

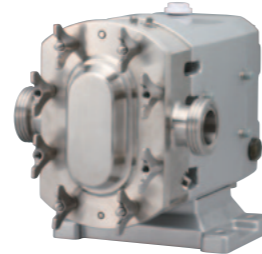

■ Customized Color



■ Buffing (Buff Finish)

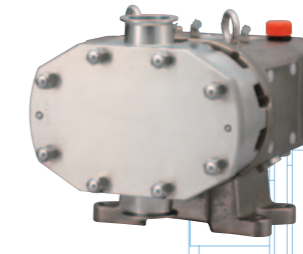

■ Nickel Coating

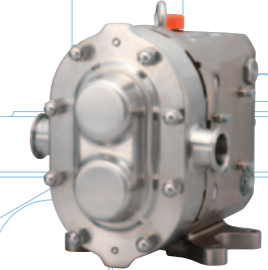

■ Super Nickel Coating

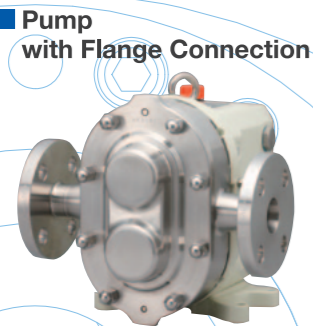

■ Pump  
with Flange Connection

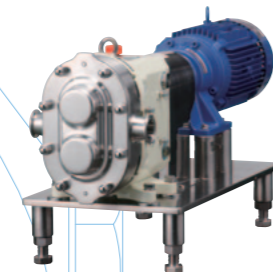

■ Pump Unit

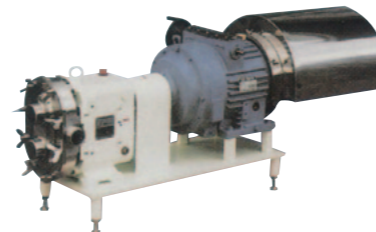

■ Unit  
with Variable Speed Changer



■ Unit with SUS Cover



■ Unit Hopper  
for High Viscosity Liquids

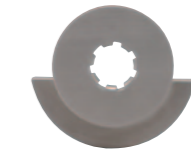

■ Single Blade Rotor

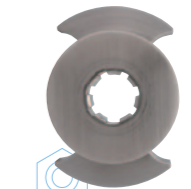

■ Double Blade Rotor

## Only Nakakin's consistent one-step production provides all customer needs.

Continuously producing pumps best meeting customer needs, Nakakin's outstanding technology is widely recognized both in Japan and overseas. As this production system is flexible, please consult us about your particular needs and special requirements.

OP/WP  
JMU  
SC  
AMXN



# JM/JO

INSIDE MECHANICAL SEAL TYPE / O-RING SEAL TYPE



## Features and Benefits

### Smallest Clearance

Special alloy "Nakamura Metal No.3" can make the smallest clearance between rotors and casing.

- Convey a constant volume of liquid.
- Self-priming
- Distribution of all levels of viscosity

### High Degree of Cleanability

Incredibly easy assembly /disassembly. Completely cleaned and sterilized with CIP & SIP processes. Standard: 95°C, High Temperature: 150°C

### Inside Seal

Precision Pump - High rigidity is reached by shortest distance between bearing and rotor.

### Mechanical Seal type

High durability and suitable for a wide variety of liquids

### O-ring Seal type

Easy to dismantle and reassemble after cleaning

### Maximum Discharge Pressure 1.5 MPa=15 bar (For details see Models Condification Chart,P14)

### Vertical and Horizontal

### Double and Single Blade Rotors

### Interchangeable with RM/RO series



## Specifications

Size	Connection	Flow Rate
4	1s	20L/min
10	1.5s	40L/min
16	1.5s	60L/min
25	1.5s	100L/min
	3s × 2s	
40	2s	135L/min
	3s × 2s	
55	2s	270L/min
	3s × 2s	
125	2.5s	410L/min
	3s	
160	4s	710L/min
200	4s	930L/min
300	6s	1470L/min

※300 is available for only JM.



## Construction Diagram

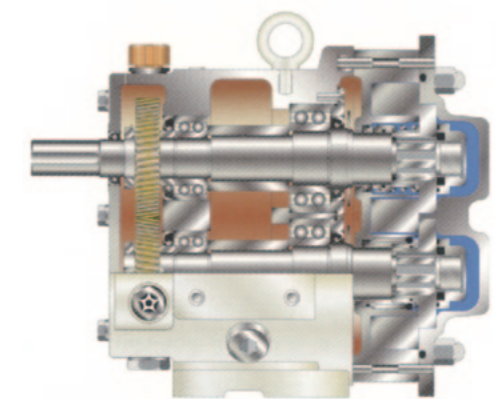

Structural Drawing p13

Codification Chart p14

Performance Curve p15

Dimensional Drawing p21



JM/JO

JMU

SC

AMXN



## Exploded view of components in contact with liquids

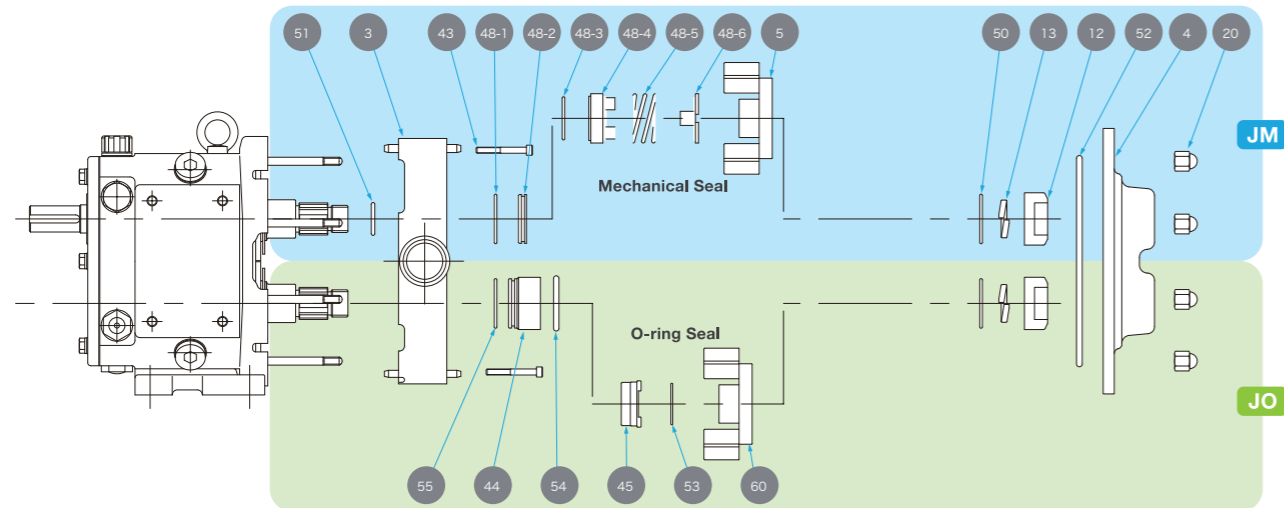

No.	Parts	No.	Parts
3	Casing	20	Hexagon cap nut
4	Casing cover	43	Cap bolt
5	Rotor	50	Nut O-ring
12	Cap nut	51	Rotor O-ring
13	Spring washer	52	Cover O-ring

JM

## Mechanical Seal Structure

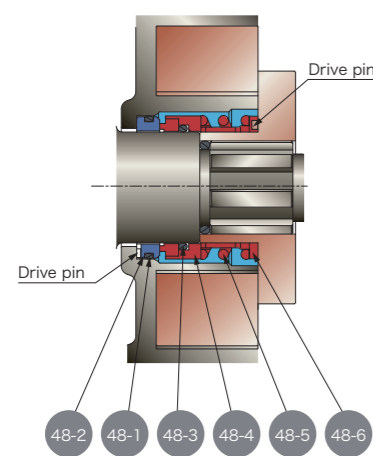

No.	Mechanical Seal
48-1	Mating ring O-ring
48-2	Mating ring
48-3	Primary ring O-ring
48-4	Primary ring
48-5	Coil spring
48-6	Spring holder

JO

## O-ring Seal Structure

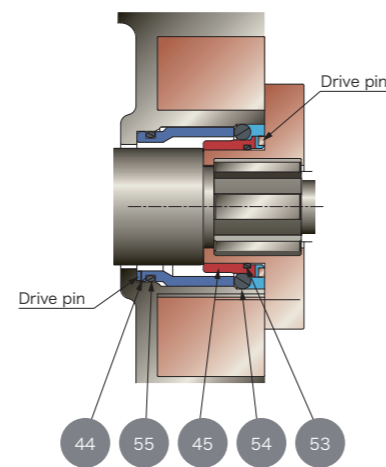

No.	O-ring Seal
44	O-ring seal collar
45	Sleeve
53	Sleeve O-ring
54	Casing O-ring
55	Collar O-ring
60	Rotor

As an example

**B JM 25 T - VT - SM - Z**

① ② ③ ④ ⑤ ⑥ ⑦

- ① Kind of Option
- ② Pump Model
- ③ Pump Size
- ④ Material of Mechanical Seal
- ⑤ Material of O-ring
- ⑥ Connection
- ⑦ Installation Option

## ① Kind of Option

Mark	Contents
B	Vented-Cover (Relief Valve)
C	CIP JET Pump Type
D	Single Blade Rotor
F	Flushing Type
G	Jacket (Casing / Casing Cover)
HP	High Pressure Pump (Max. 20 bar) ※JM25,55 Only
K	Rectangular Port
KZ	Rectangular Port with Slit for O-ring ※J25 ~ 55 Only
N	Smaller Clearance
OB	Air Vented Cover
S	Vacuum Type ※JM Series Only
V	Vertical Type
W	Double O-ring Seal Type ※JO Series Only
T	Titanium Pump

## ② Pump Model

Mark	Contents
JM	STANDARD TYPE with Inside Mechanical Seal Pump
JO	STANDARD TYPE with O-ring Seal Pump

## ③ Pump Size

JM/JO Series						
Size	Port	Max Speed (rpm)	Max Capacity (L/min)	Displacement (L/rev)	Max. Pressure (Standard Pump) (bar)	Max. Pressure ("HP" Pump)(bar) ※JM Only
4	1"	800	20	0.025	7	—
10	1 1/2"	800	40	0.050	15	10
16	1 1/2"	600	60	0.100	15	10
25	1 1/2"	450	100	0.220	15	10
40	2"	450	135	0.300	15	10
55	2"	450	270	0.600	15	10
125	2 1/2"	450	410	0.920	15	10
160	4"	450	710	1.580	15	10
200	4"	450	930	2.060	15	10
300	6"	450	1470	3.270	15	—

JM JO

## ④ Material of Mechanical Seal (JM Series Only)

Mark	Material
No Mark	Carbon&Ceramic
T	Tungsten Carbide & Tungsten Carbide
SS	Silicon Carbide & Silicon Carbide
SNT	Knife-Edge Silicon Carbide & Tungsten Carbide
T2	Tungsten Carbide & Tungsten Carbide for Liquid Sugar
... Further Materials on Request	

## ⑤ Material of O-ring

Mark	Material
No Mark	NBR
VT	FKM
EP	EPDM
SI	Silicon
K	Kalrez
Y	PTFE

## ⑥ Connection

Mark	Contents
D	DIN11851
SM	SMS
DF	DIN Flange
TC	Tri-Clamp (ISO2852)
C	Clamp
F	Flange (Japanese Standard)
Z+Connection Mark	Different Port Size
... Further Connection Type on Request	

## ⑦ Installation Option

Mark	Contents
Z	Special Option (e.g.)
	- SUS316L/ Hastelloy (Wetted Materials)
	- SUS316/ SUS316L (Rotors)
	- Electrical Polish
	- Roughness of Surface (Ra≤0.8)
	- Left Thread Shaft
	- Umbrella Rotors (e.g. Chocolate, Paste)
- Special Material for Sleeve (Titanium Coating) ※JO Series Only	
- Nickel Coating for Housing	
... Further Options on Request	
CW	- Churning measure (e.g. Cream)
3A	- 3A Approved ※JM Series Only



# JM/JO Performance Curve

## JM/JO4

**PORT SIZE PRODUCT**  
1" Water & Newtonian fluid

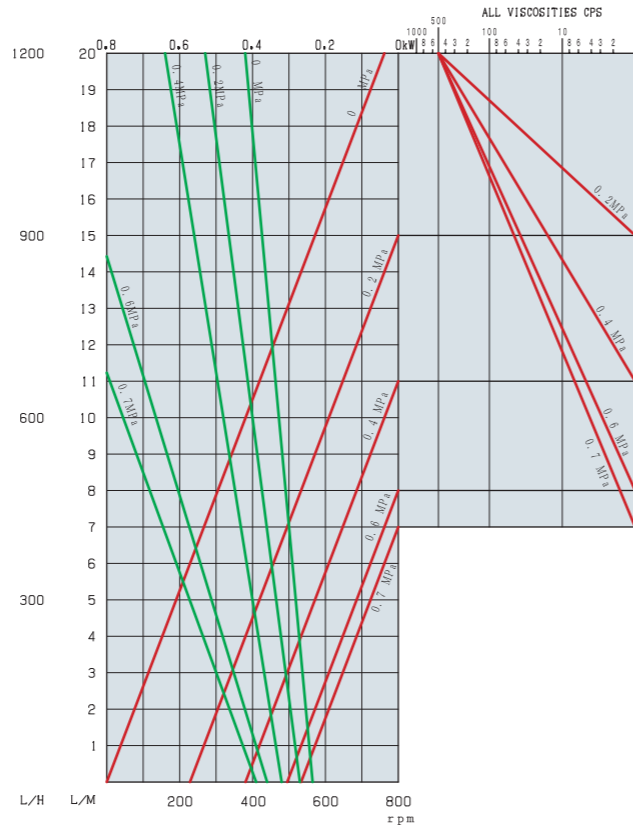

## JM/JO16

**PORT SIZE PRODUCT**  
1.5" Water & Newtonian fluid

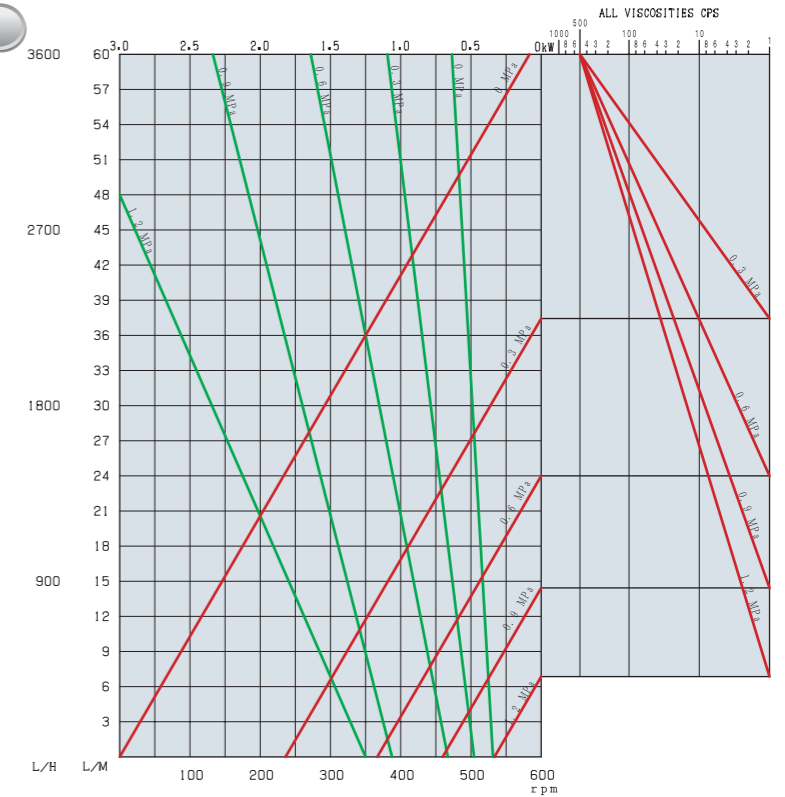

## JM/JO10

**PORT SIZE PRODUCT**  
1.5" Water & Newtonian fluid

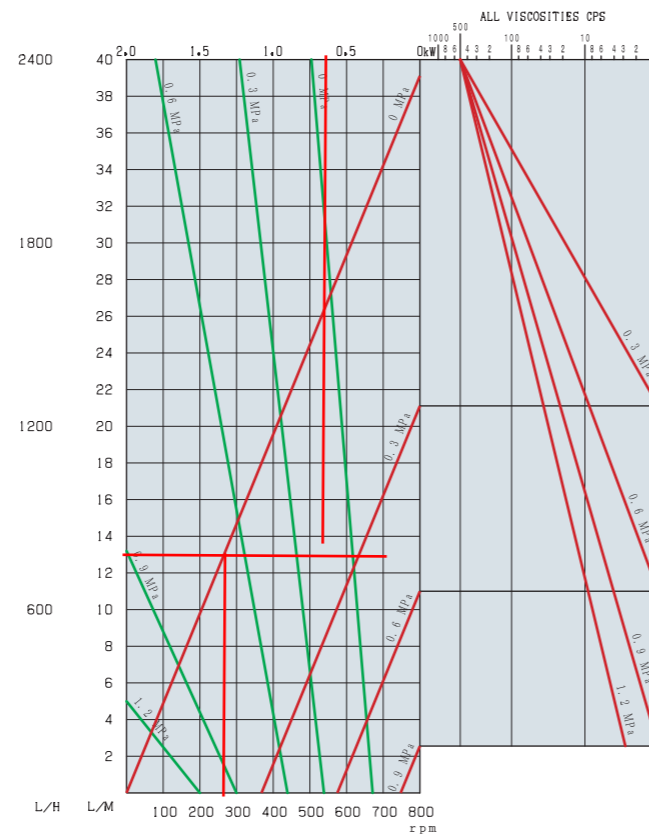

## JM/JO25

**PORT SIZE PRODUCT**  
1.5" Water & Newtonian fluid

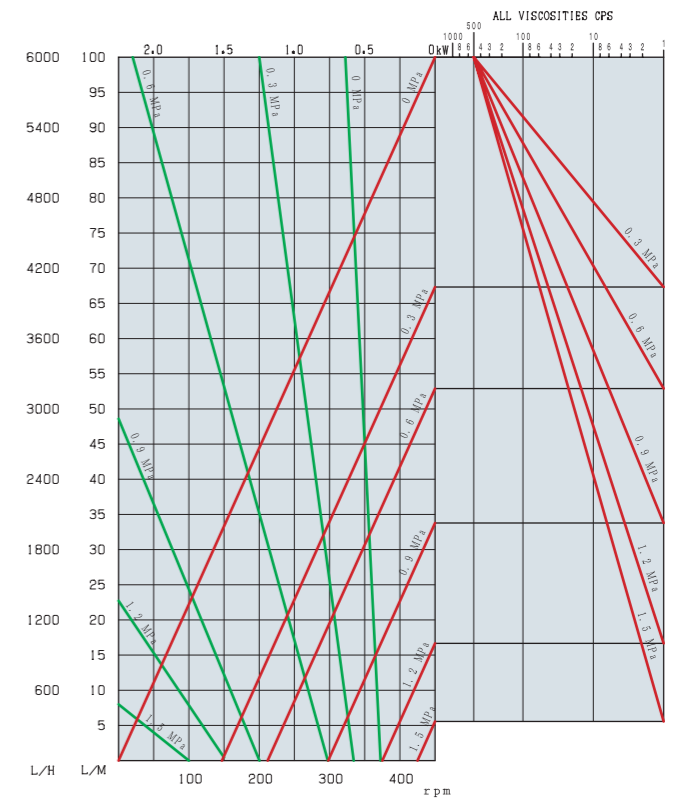

※Actual performance may vary by application or product. ※Refer to page 20 for the interpretation of the chart.



# JM/JO Performance Curve

## JM/JO40

**PORT SIZE PRODUCT**  
2" Water & Newtonian fluid

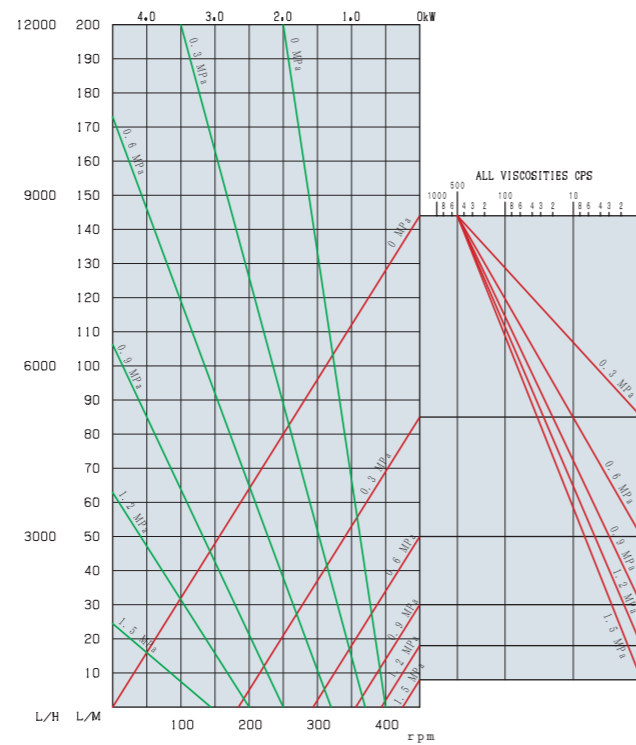

## JM/JO125

**PORT SIZE PRODUCT**  
2.5" Water & Newtonian fluid

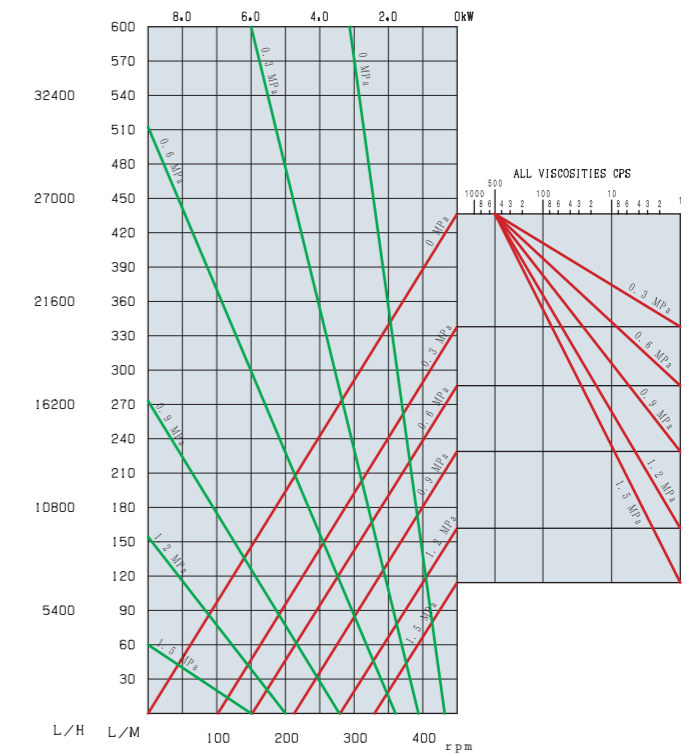

## JM/JO55

**PORT SIZE PRODUCT**  
2" Water & Newtonian fluid

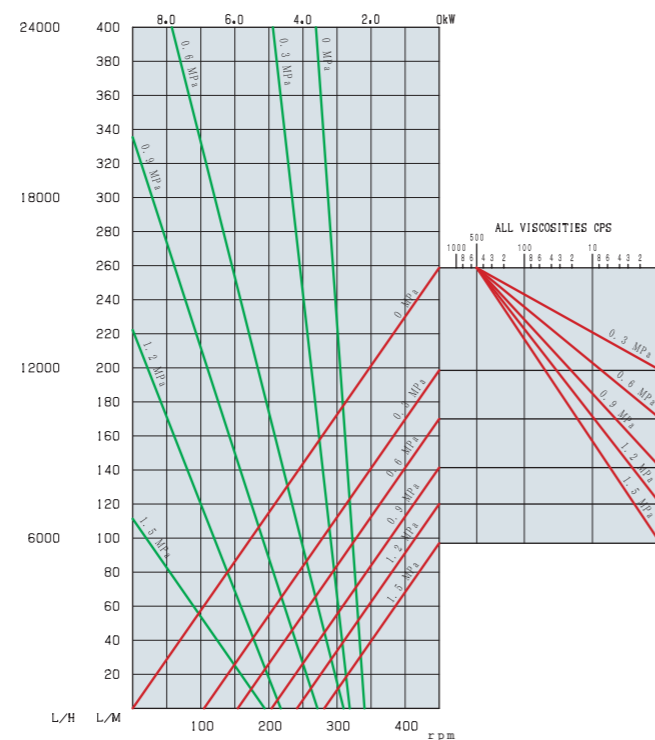

## JM/JO160

**PORT SIZE PRODUCT**  
4" Water & Newtonian fluid

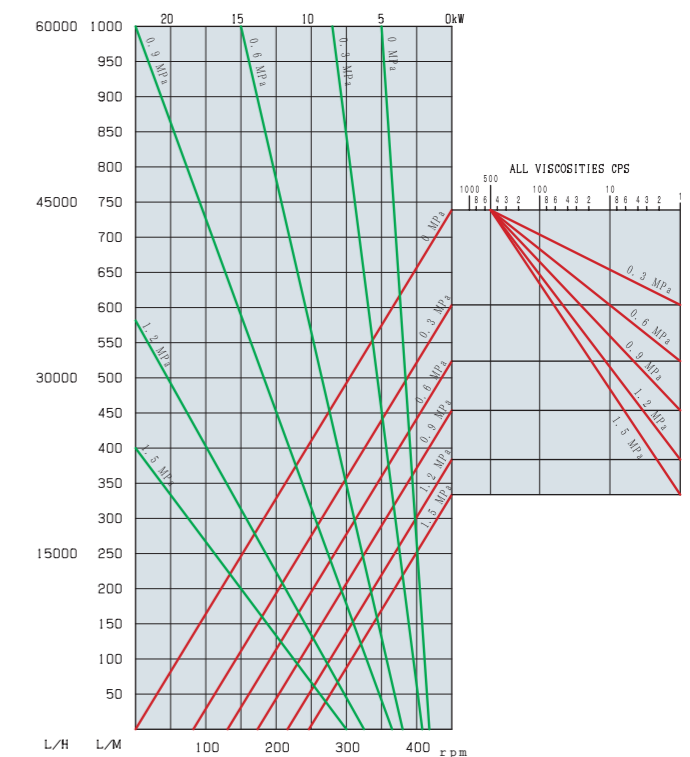

※Actual performance may vary by application or product. ※Refer to page 20 for the interpretation of the chart.

# JM/JO Performance Curve

JM/JO200

PORT SIZE 4"  
PRODUCT Water & Newtonian fluid

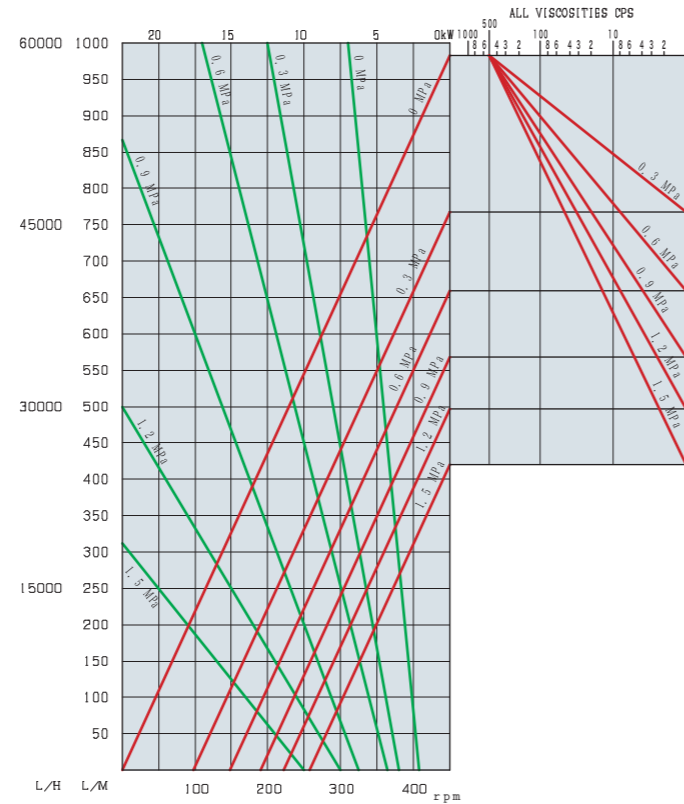

JM300

PORT SIZE 6"  
PRODUCT Water & Newtonian fluid

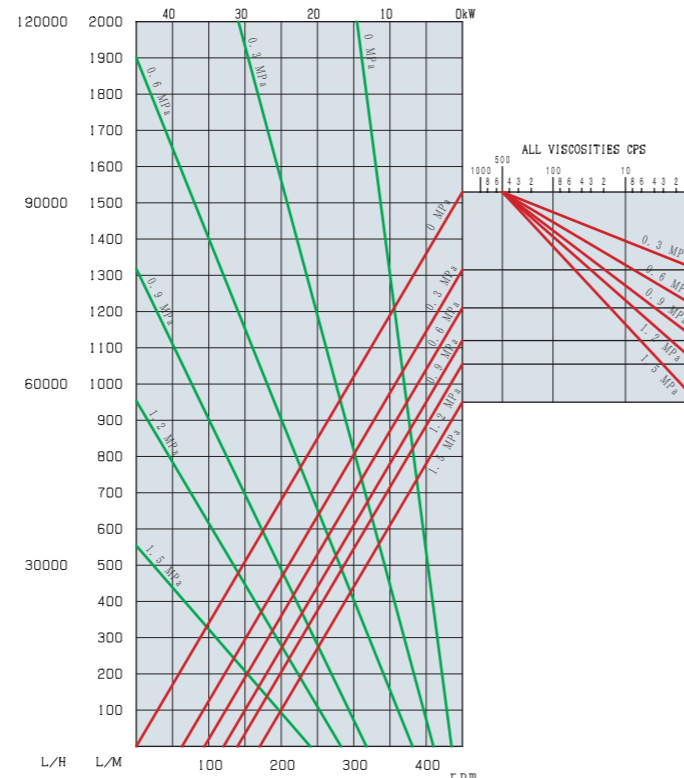

## How to Use the Performance Curve

Under the following conditions:  
Flow rate: 30 L/min, discharge pressure: 0.6 MPa and viscosity: 10 CPS

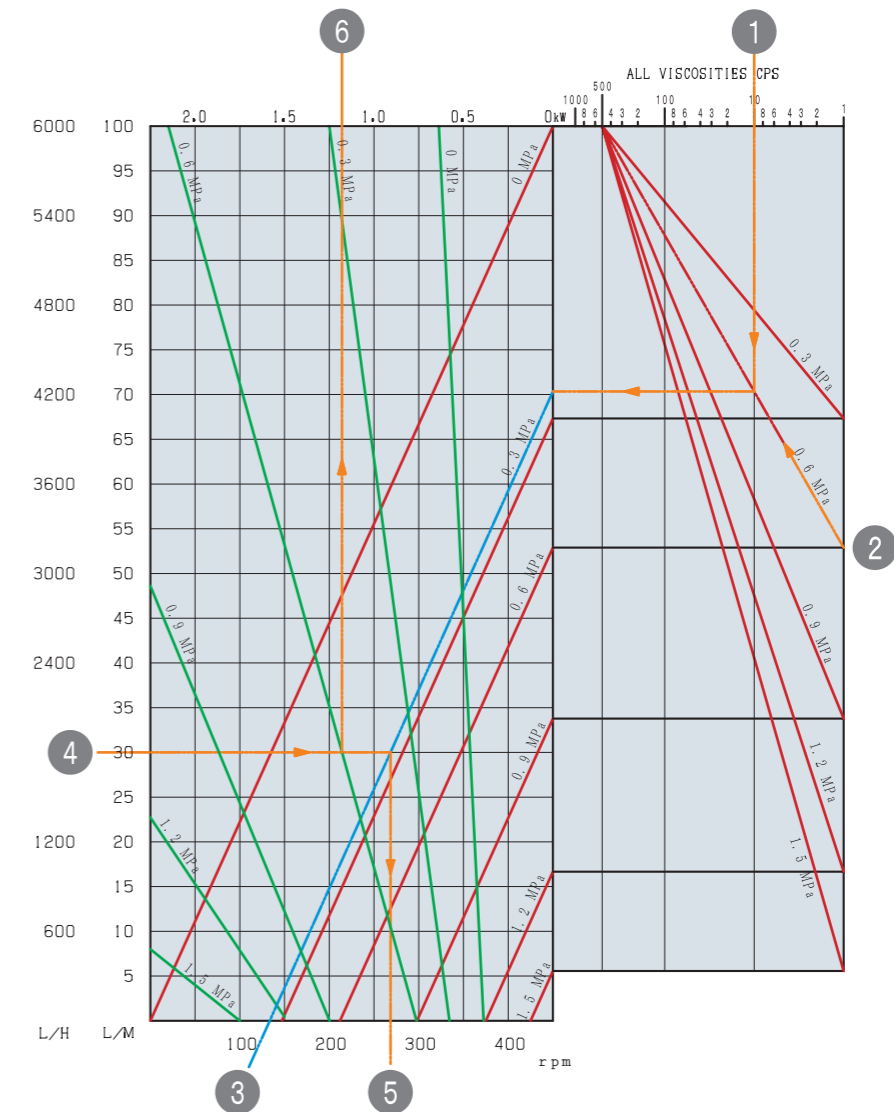

1. Come straight down (in the direction of ↓) from ① on "ALL VISCOSITIES CPS" in the upper right corner.
2. When reaching the 0.6 MPa line ②, move to direction of ←.
3. When reaching the rightmost grid of the diagram, draw line ③ in parallel with it.
4. From the intersection of 30 L/min line ④ and line ③, come straight down (in the direction of ↓) to draw line ⑤ and obtain the rotational speed of 270 rpm.
5. From the intersection of 30 L/min line ④ and the 0.6MPa power line, go up straight in the direction of ↑ to draw line ⑥ and obtain the power (1.2 kW).

※Actual performance may vary by application or product. ※Refer to page 20 for the interpretation of the chart.



# JM/JO

# Dimensional Drawing

JM/JO Series

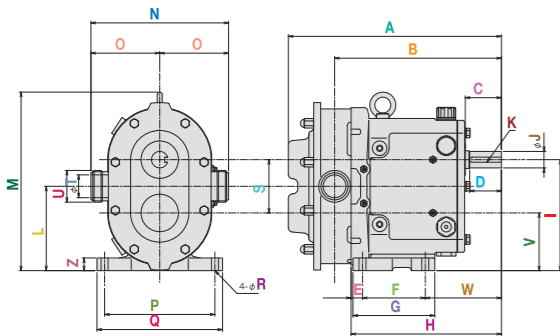

Type Mark	JO	JM(O)	JM(O)	JM(O)	JM(O)	JM(O)	JM(O)	JM(O)	JM(O)	JM
A	238	323	323	336	355	407	437	566	853	
B	195	249	246	263	276	322.5	345	440.5	695	
C	34	62	60	58	58	63	63	75	110	
D	30	50	50	50	50	54	54	70	100	
E	23	15	15	18	18	30	30	25	85	
F	75	80	80	99	99	115	115	198	265	
G	95	108	108	129	129	155	155	238	335	
H	183	218	218	237	237	295	295	388	617	
I	100	140	140	175	175	243	243	314	400	
J	18	22	22	26	26	36	36	55	70	
K	Width	6	6	8	8	10	10	16	22	
	Depth	3.5	3.5	3.5	4	4	5	5	6	9
L	76	107.5	107.5	133	133	185.5	185.5	237	307.5	
M	161	237	237	282	282	380	380	506	667	
N	167	180	180	217	217	270	270	380	500	
O	83.5	90	90	108.5	108.5	135	135	190	250	
P	132	150	150	174	174	230	230	280	370	
Q	154	174	174	198	198	260	260	320	420	
R	9	11	11	11	11	14	14	18	23	
S	48	65	65	84	84	115	115	154	185	
T	19	24	30	36	47	47	60	96	150	
U	1s	1.5s	1.5s	1.5s	2s	2s	2.5s	4s	6s	
V	52	75	75	91	91	128	128	160	215	
W	85	123	123	120	120	150	150	165	267	
Z	11	18	18	20	20	23	23	23	30	
Weight	15kg	27.5kg	28kg	42kg	45kg	85.7kg	94.4kg	140kg	420kg	

K/KZJ Series

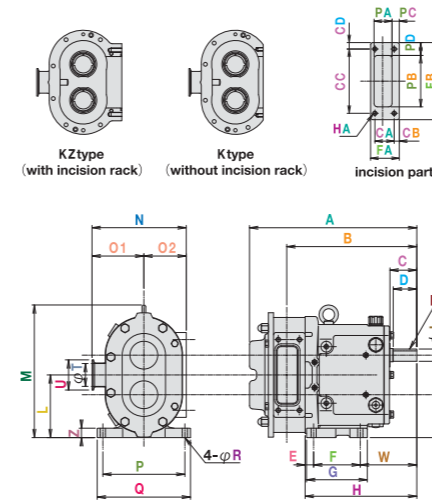

Type Mark	K	K	KZ	KZ	KZ	K	K	K
A	323	323	336	355	407	437	566	566
B	249	246	263	276	322.5	345	440.5	440.5
C	62	60	58	58	63	63	75	75
D	50	50	50	50	54	54	70	70
E	15	15	18	18	30	30	25	25
F	80	80	99	99	115	115	198	198
G	108	108	129	129	155	155	238	238
H	218	218	237	237	295	295	388	388
I	140	140	175	175	243	243	314	314
J	22	22	26	26	36	36	55	55
K	Width	6	8	8	10	10	16	16
	Depth	3.5	3.5	4	4	5	5	6
L	107.5	107.5	133	133	185.5	185.5	237	237
M	237	237	282	282	380	380	506	506
N	140	140	200	200	275	238	325	325
O1	90	90	110	110	135	135	190	190
O2	50	50	90	90	140	103	135	135
P	150	150	174	174	230	230	280	280
Q	174	174	198	198	260	260	320	320
R	11	11	11	11	14	14	18	18
T	24	30	36	47	47	60	96	96
U	1.5s	1.5s	2s	2s	2s	3s	4s	4s
W	123	123	120	120	150	150	165	165
Z	18	18	20	20	23	23	23	23
Incision part								
CA	13	24	28	45	40	50	42	62
CB	28	16	10	12	12.5	25	48	28
CC	130	130	150	150	145	155	184	184
CD	6.5	6.5	15	15	15	9	18	18
FA	46	46	48	67	65	85	105	105
FB	143	143	180	180	175	173	220	220
PA	16	26	27	42	43	52	51.5	71.5
PB	90	90	120	120	110	115	137	137
PC	26	16	13	17	11	23	45	25
PD	26.5	26.5	30	30	32.5	29	41.5	41.5
HA	M6	M6	M10	M10	M12	M10	M12	M12
Flange part seal system	Plate packing	Plate packing	O-ring	O-ring	O-ring	Plate packing	Plate packing	Plate packing

VJM/VJO Series

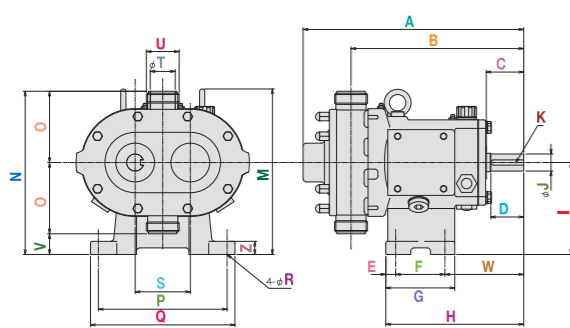

Type Mark	VJO	VJM(O)	VJM(O)	VJM(O)	VJM(O)	VJM(O)	VJM(O)	VJM(O)	VJM
A	238	323	323	336	355	407	437	566	872
B	195	249	246	263	276	322.5	345	440.5	702
C	34	62	62	58	58	63	63	75	110
D	30	50	50	50	50	54	54	70	100
E	10	15	15	15	15	20	20	20	35
F	58	60	60	75	75	125	125	153	235
G	78	90	90	105	105	165	165	193	305
H	153	199	199	210	210	295	295	338	502
I	100	113	113	140	140	150	150	200	300
J	18	22	22	26	26	36	36	55	70
K	Width	6	6	8	8	10	10	16	22
	Depth	3.5	3.5	3.5	4	4	5	5	6
M	175	220	220	252	252	291	291	380	516
N	167	203	203	248.5	248.5	285	285	390	550
O	83.5	90	90	108.5	108.5	135	135	190	250
P	132	170	170	196	196	280	280	360	400
Q	154	196	196	220	220	310	310	400	470
R	9	11	11	11	11	17	17	19	23
S	48	65	65	84	84	115	115	154	185
T	19	24	30	36	46	46	60	96	150
U	1s	1.5s	1.5s	1.5s	2s	2s	2.5s	4s	6s
V	16.5	23	23	31.5	31.5	15	15	10	50
W	85	124	124	120	120	150	150	165	267
Z	12	18	18	20	20	23	23	23	30
Weight	16.0kg	28.6kg	29.2kg	44.3kg	47.2kg	89.8kg	98.2kg	160kg	450kg

KV/KZVJ Series

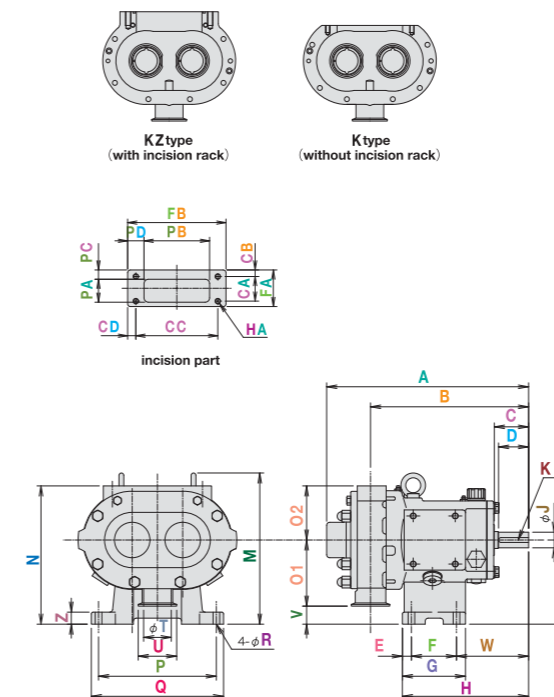

Type Mark	K	K	KZ	KZ	KZ	K	K	K
A	323	323	336	355	437	437	566	566
B	249	246	263	276	322.5	345	440.5	440.5
C	62	62	58	58	63	63	75	75
D	50	50	50	50	54	54	70	70
E	15	15	15	15	20	20	20	20
F	60	60	75	75	125	125	153	153
G	90	90	105	105	165	165	193	193
H	199	199	210	210	295	295	338	338
I	113	113	140	140	150	150	200	200
J	22	22	26	26	36	36	55	55
K	Width	6	8	8	10	10	16	16
	Depth	3.5	3.5	4	4	5	5	6
M	220	220	252	252	291	291	364	364
N	163	163	230	230	290	254	335	335
O1	90	90	110	110	135	135	190	190
O2	50	50	90	90	140	103	135	135
P	170	170	196	196	280	280	360	360
Q	196	196	220	220	310	310	400	400
R	11	11	11	11	17	17	19	19
T	24	30	36	46	46	60	96	96
U	1.5s	1.5s	2s	2s	2s	3s	4s	4s
V	23	23	30	30	15	15	10	10
W	124	124	120	120	150	150	165	165
Z	18	18	20	20	23	23	23	23
Incision part								
CA	13	24	28	45	40	50	42	62
CB	28	16	10	12	12.5	25	48	28
CC	130	130	150	150	145	155	184	184
CD	6.5	6.5	15	15	15	9	18	18
FA	46	46	48	67	65	85	105	105
FB	143	143	180	180	175	173	220	220
PA	16	26	27	42	43	52	51.5	71.5
PB	90	90	120	120	110	115	137	137
PC	26	16	13	17	11	23	45	25
PD	26.5	26.5	30	30	32.5	29	41.5	41.5
HA	M6	M6	M10	M10	M12	M10	M12	M12
Flange part seal system	Plate packing	Plate packing	O-ring	O-ring	O-ring	Plate packing	Plate packing	Plate packing

※Size and weight may be changed without prior notice.



### Features and Benefits

#### Smallest Clearance

Special alloy "Nakamura Metal No.3" can make the smallest clearance between rotors and casing.

- Convey a constant volume of liquid.
- Self-priming
- Distribution of all levels of viscosity

#### High Degree of Cleanability

Incredibly easy assembly /disassembly. Completely cleaned and sterilized with CIP & SIP processes. Standard: 95°C, High Temperature: 150°C

#### Outside Seal

High Cleanability - A few parts in a wet area can be dismantled and reassembled easily.

#### Single Mechanical Seal type

Standard.

#### Quench Seal type

Quenching Seal by Oil Seal. Moderate price compared to Tandem. (0.03 MPa=0.3 bar)

#### Tandem Seal type

Quenching Seal by Mechanical Seal. Steam is available. (0.25 MPa=2.5 bar)

#### Maximum Discharge Pressure 1.0 MPa=10 bar (For details see Models Condification Chart,P26)

#### Vertical and Horizontal

#### Double and Single Blade Rotors



### Specifications

Size	Connection	Flow Rate
4	1s	20L/min
10	1.5s	40L/min
16	1.5s	60L/min
25	1.5s	100L/min
40	2s	135L/min
55	2s	270L/min
125	2.5s	410L/min
160	4s	710L/min
200	4s	930L/min
300	6s	1470L/min



### Construction Diagram

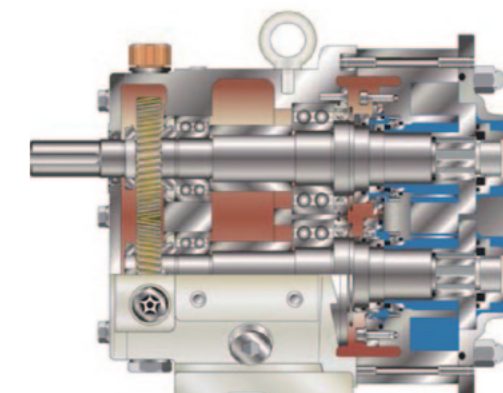

Structural Drawing p25

Codification Chart p26

Performance Curve p27

Dimensional Drawing p30

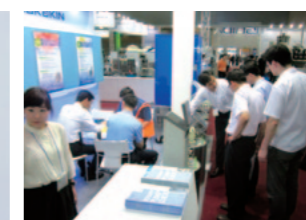



## Exploded view of components in contact with liquids

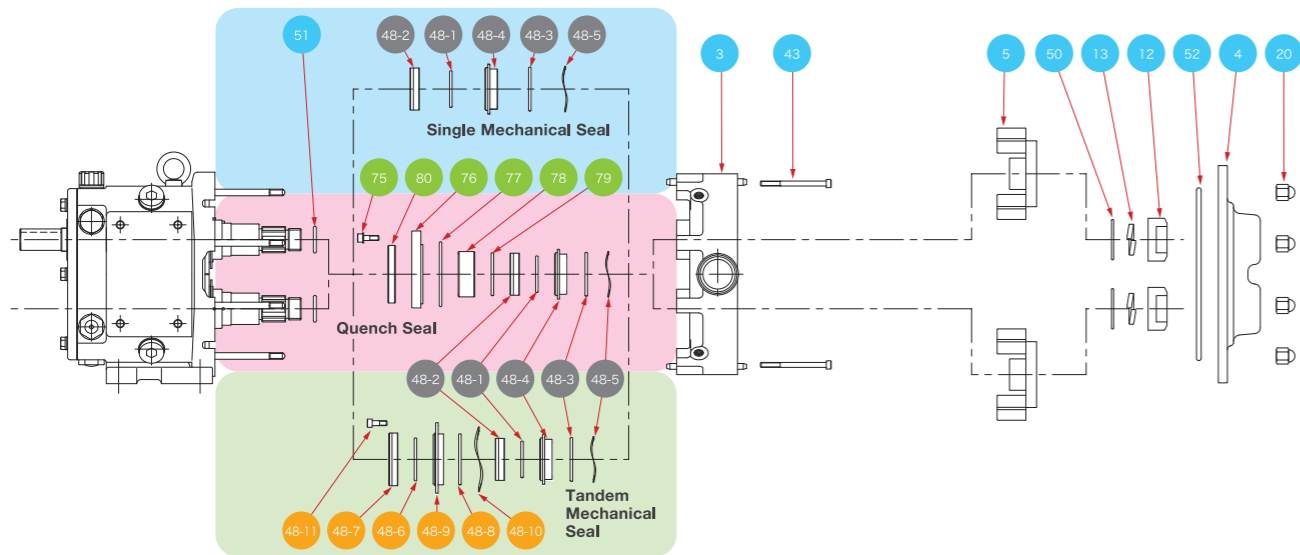

No.	Parts	No.	Parts
3	Casing	20	Hexagon cap nut
4	Casing cover	43	Cap bolt
5	Rotor	50	Nut O-ring
12	Cap nut	51	Rotor O-ring
13	Spring washer	52	Cover O-ring

### Single Mechanical Seal Structure

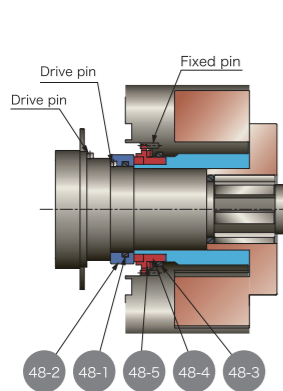

No.	Mechanical Seal Parts on Pump Side
48-1	Mating ring O-ring
48-2	Mating ring
48-3	Primary ring O-ring
48-4	Primary ring
48-5	Wave spring

### Quench Seal Structure

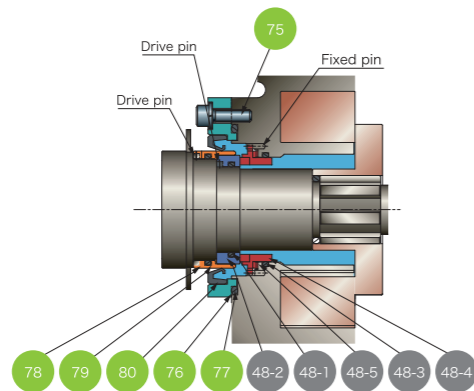

No.	Quench Seal Parts on Atmospheric Side
75	Cap bolt
76	Oil seal retainer
77	Retainer O-ring
78	Quench sleeve
79	Sleeve O-ring
80	Oil seal

### Tandem Mechanical Seal Structure

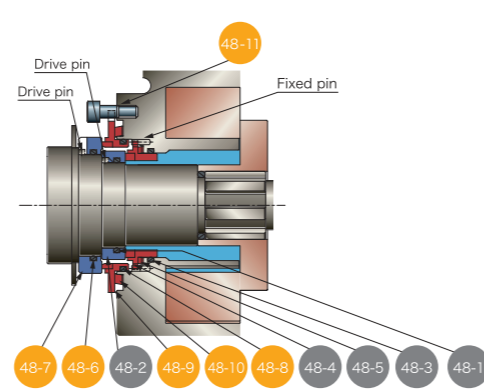

No.	Mechanical Seal Parts on Atmospheric Side
48-6	Mating ring O-ring
48-7	Mating ring
48-8	Primary ring O-ring
48-9	Primary ring
48-10	Wave spring
48-11	Cap bolt

As an example

**B JMU 25 T-VT-SM-Z**

① ② ③ ④ ⑤ ⑥ ⑦

- ① Kind of Option
- ② Pump Model
- ③ Pump Size
- ④ Material of Mechanical Seal
- ⑤ Material of O-ring
- ⑥ Connection
- ⑦ Installation Option

### ① Kind of Option

Mark	Contents
B	Vented-Cover (Relief Valve)
C	CIP JET Pump Type
D	Single Blade Rotor
F	Flushing Type
G	Jacket (Casing / Casing Cover)
HP	High Pressure Pump (Max. 15 bar) ※10~300 Only
HT	High Temperature Type (Max. 150°C)
K	Rectangular Port
KZ	Rectangular Port with Slit for O-ring ※2JMU Only 16,40,125,200
N	Smaller Clearance
OB	Air Vented Cover
Q	Quenching
S	Vacuum Type
V	Vertical Type
W	Tandem-Seal Type ※Except 2JMU
T	Titanium Pump

### ② Pump Model

Model	Contents
JMU	Outside Mechanical Seal Pump

### ③ Pump Size

JMU Series						
Size	Port	Max Speed (rpm)	Max Capacity (L/min)	Displacement (L/rev)	Max. Pressure (Standard Pump) (bar)	Max. Pressure ("HP" Pump) (bar)
4	1"	800	20	0.025	7	-
10	1 1/2"	800	40	0.050	10	15
16	1 1/2"	600	60	0.100	10	15
25	1 1/2"	450	100	0.220	10	15
40	2"	450	135	0.300	10	15
55	2"	450	270	0.600	10	15
125	2 1/2"	450	410	0.920	10	15
160	4"	450	710	1.580	10	15
200	4"	450	930	2.060	10	15
300	6"	450	1470	3.270	10	15

### ④ Material of Mechanical Seal

Mark	Material
No Mark	Carbon&Ceramic
T	Tungsten Carbide & Tungsten Carbide
SS	Silicon Carbide & Silicon Carbide
SNT	Knife-Edge Silicon Carbide & Tungsten Carbide
T2	Tungsten Carbide & Tungsten Carbide for Liquid Sugar ※Except 2JMU

... Further Materials on Request

### ⑤ Material of O-ring

Mark	Material
No Mark	NBR
VT	FKM
EP	EPDM
SI	Silicon
K	Kalrez
Y	PTFE

### ⑥ Connection

Mark	Contents
D	DIN11851
SM	SMS
DF	DIN Flange
TC	Tri-Clamp (ISO2852)
C	Clamp
F	Flange (Japanese Standard)
Z+Connection Mark	Different Port Size

... Further Connection Type on Request

### ⑦ Installation Option

Mark	Contents
Z	Special Options (e.g.)
	- SUS316L/ Hastelloy (Wetted Materials)
	- SUS316/ SUS316L (Rotors)
	- Electrical Polish
	- Roughness of Surface (Ra≤0.8)
	- Left Thread Shaft
	- Umbrella Rotors (e.g. Chocolate, Paste)
- Nickel Coating for Housing	
...	Further Options on Request
CW	- Churning measure (e.g. Cream)
3A	- 3A Approved
EH	- EHEDG Approved

# JMU Performance Curve

**JMU4**

**PORT SIZE** 1"  
**PRODUCT** Water & Newtonian fluid

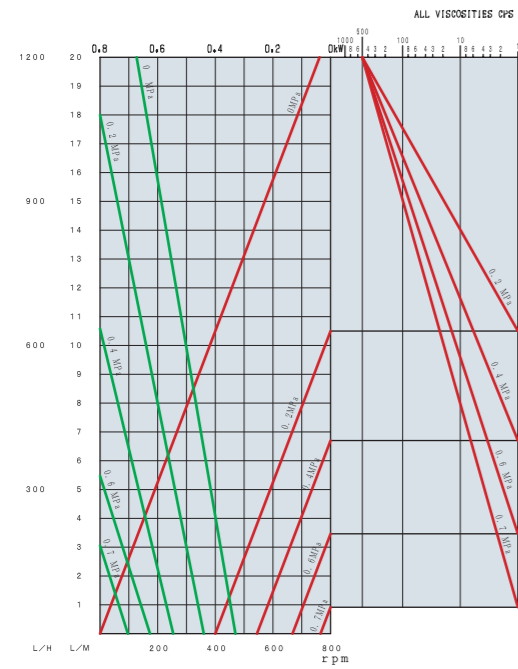

**JMU16**

**PORT SIZE** 1.5"  
**PRODUCT** Water & Newtonian fluid

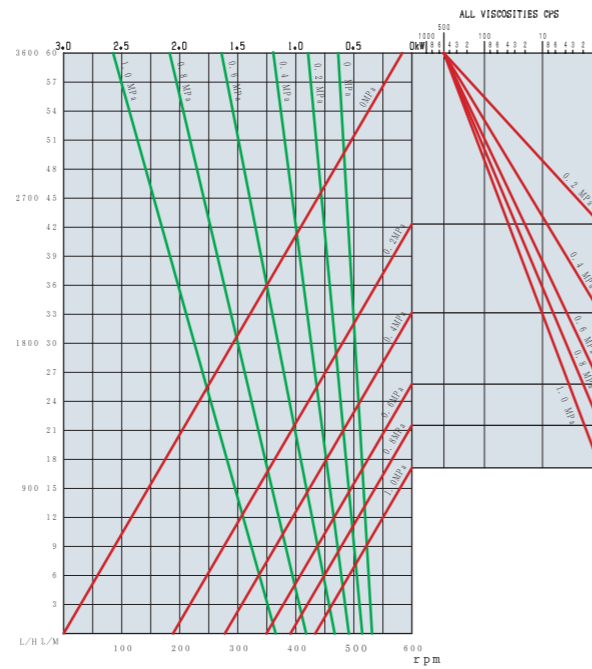

**JMU40**

**PORT SIZE** 2"  
**PRODUCT** Water & Newtonian fluid

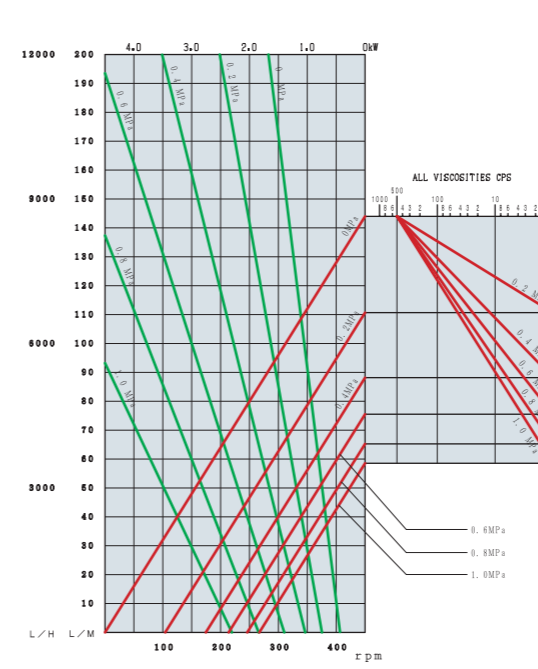

**JMU125**

**PORT SIZE** 2.5"  
**PRODUCT** Water & Newtonian fluid

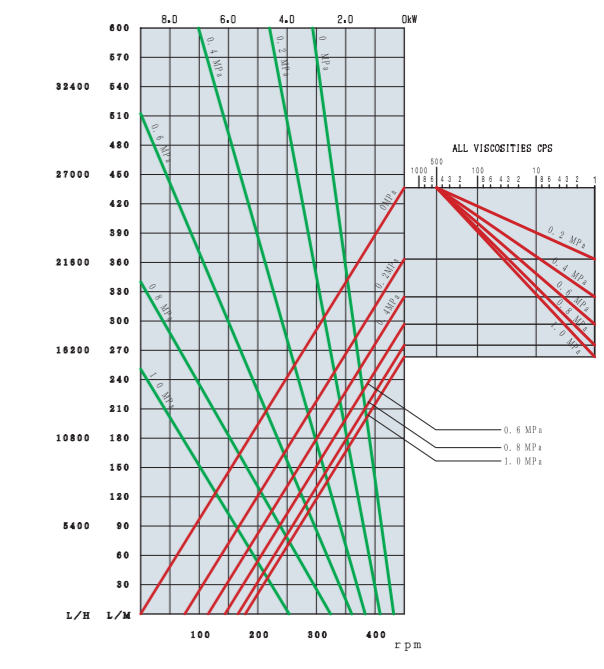

**JMU10**

**PORT SIZE** 1.5"  
**PRODUCT** Water & Newtonian fluid

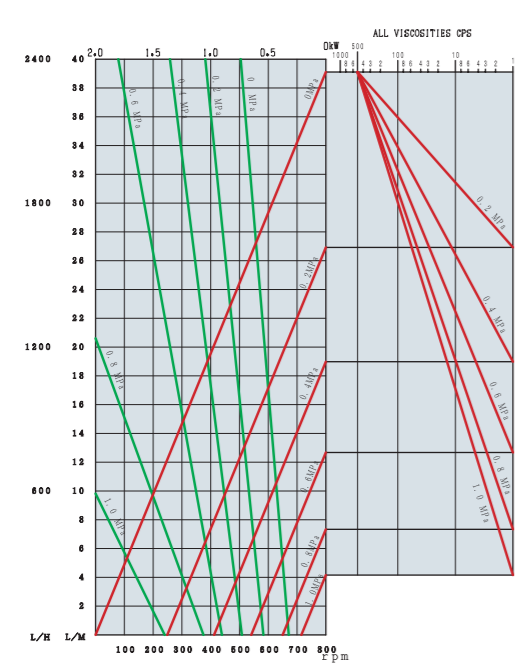

**JMU25**

**PORT SIZE** 1.5"  
**PRODUCT** Water & Newtonian fluid

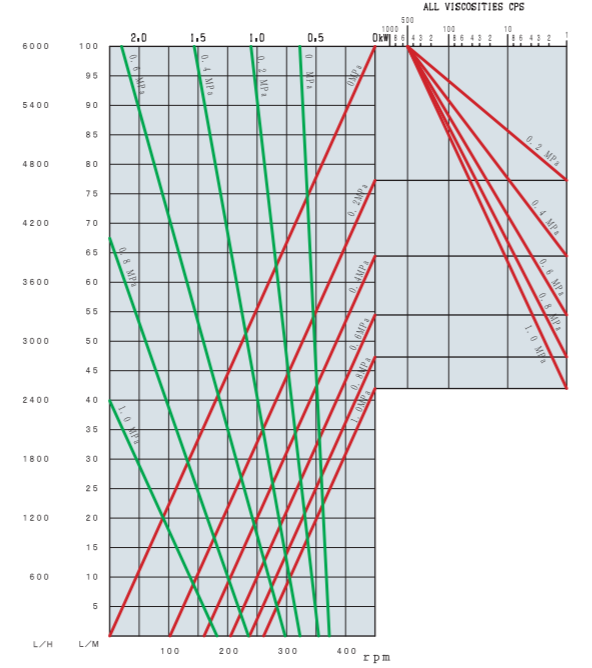

**JMU55**

**PORT SIZE** 2"  
**PRODUCT** Water & Newtonian fluid

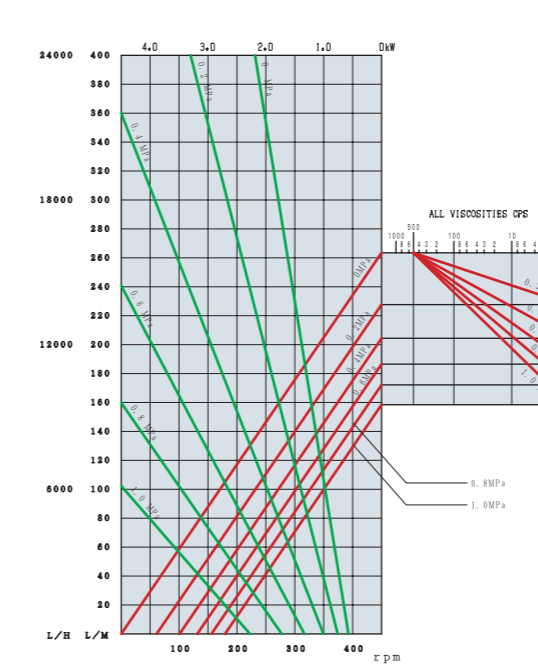

**JMU160**

**PORT SIZE** 4"  
**PRODUCT** Water & Newtonian fluid

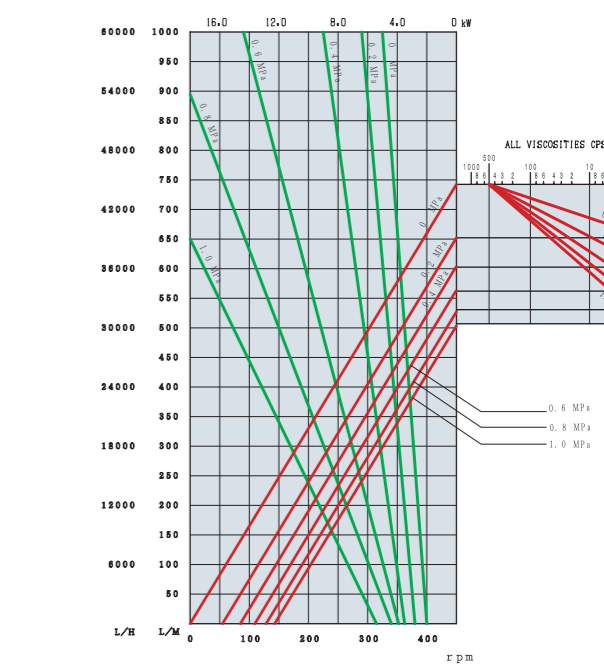

※Actual performance may vary by application or product. ※Refer to page 20 for the interpretation of the chart.



# JMU Performance Curve

# JMU Dimensional Drawing

## JMU200

**PORT SIZE PRODUCT**  
4" Water & Newtonian fluid

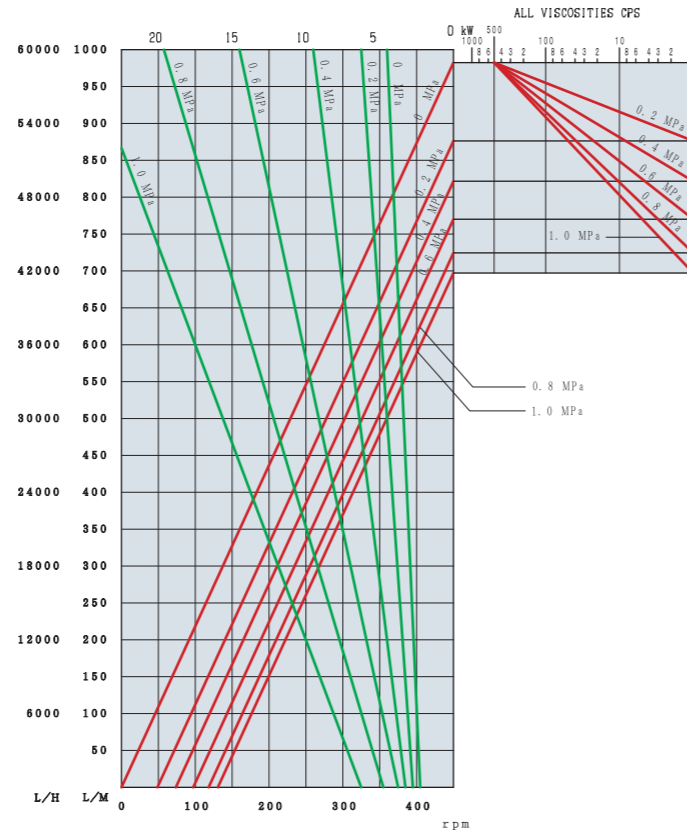

## JMU Series

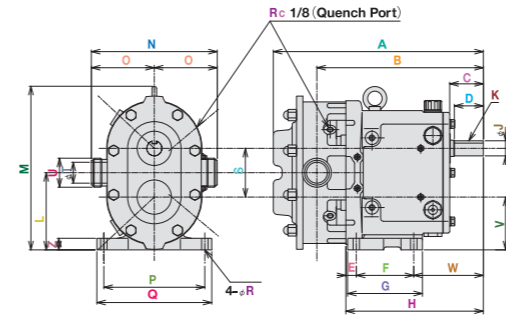

Type Mark	JMU 4	JMU 10	JMU 16	JMU 25	JMU 40	JMU 55	JMU 125	JMU 160-200	JMU 300
A	254.5	328	328	362	372	432	458	613	853
B	207	271	266	287	291	347.5	364	464	695
C	34	62	60	58	58	63	63	75	110
D	30	50	50	50	50	54	54	70	100
E	23	15	15	18	18	30	30	25	85
F	75	80	80	99	99	115	115	198	265
G	95	108	108	129	129	155	155	238	335
H	183	218	218	237	237	295	295	388	617
I	100	140	140	175	175	243	243	314	400
J	18	22	22	26	26	36	36	55	70
K	Width	6	6	8	8	10	10	16	22
	Depth	3.5	3.5	3.5	4	5	5	6	9
L	76	107.5	107.5	133	133	185.5	185.5	237	307.5
M	161	237	237	282	282	380	380	506	667
N	167	180	180	217	217	270	270	380	500
O	83.5	90	90	108.5	108.5	135	135	190	250
P	132	150	150	174	174	230	230	280	370
Q	154	174	174	198	198	260	260	320	420
R	9	11	11	11	11	14	14	18	23
S	48	65	65	84	84	115	115	154	185
T	19	24	24	36	47	47	60	96	150
U	1s	1.5s	1.5s	1.5s	2s	2s	2.5s	4s	6s
V	2	75	91	91	128	128	160	215	
W	85	123	123	120	120	150	150	165	267
Z	11	18	18	20	20	23	23	23	30

## JMU300

**PORT SIZE PRODUCT**  
6" Water & Newtonian fluid

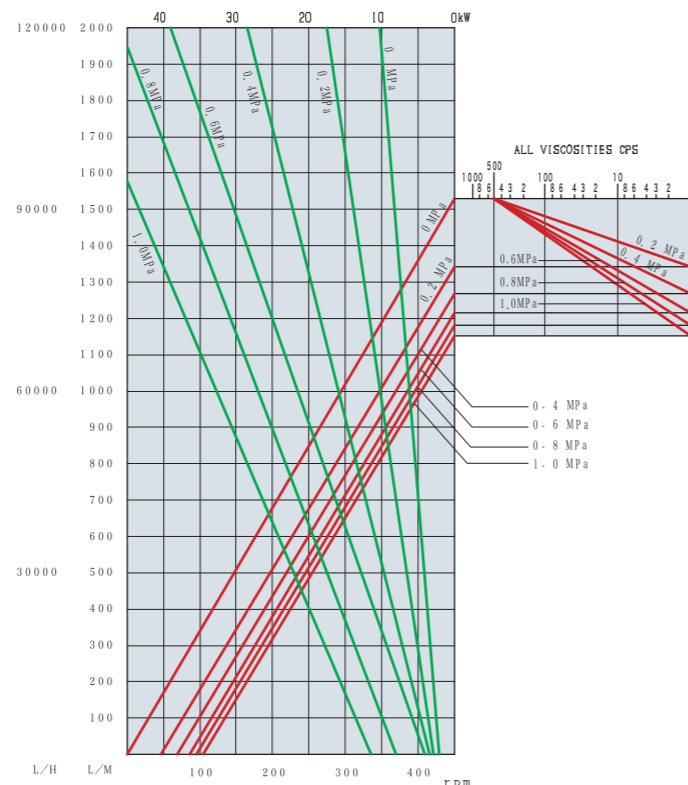

## VJMU Series

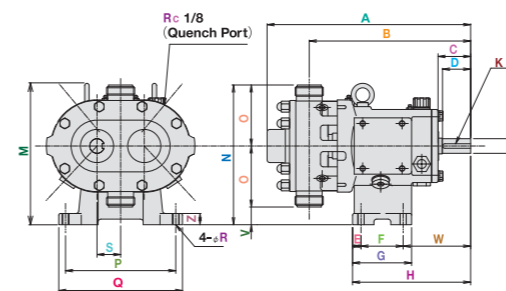

Type Mark	VJMU 4	VJMU 10	VJMU 16	VJMU 25	VJMU 40	VJMU 55	VJMU 125	VJMU 160-200	VJMU 300
A	254.5	328	328	362	372	432	458	592	872
B	207	271	266	287	291	347.5	364	464	702
C	34	62	60	58	58	63	63	75	110
D	30	50	50	50	50	54	54	70	100
E	10	15	15	15	15	20	20	20	35
F	58	60	60	75	75	125	125	153	235
G	78	90	90	105	105	165	165	193	305
H	153	199	199	210	210	295	295	338	502
I	100	113	113	140	140	150	150	200	300
J	18	22	22	26	26	36	36	55	70
K	Width	6	6	8	8	10	10	16	22
	Depth	3.5	3.5	3.5	4	5	5	6	9
M	175	220	220	252	252	291	291	380	516
N	183.5	203	203	248.5	248.5	285	285	390	550
O	83.5	90	90	108.5	108.5	135	135	190	250
P	132	170	170	196	196	280	280	360	400
Q	154	196	196	220	220	310	310	400	470
R	9	11	11	11	11	17	17	19	23
S	24	32.5	32.5	42	42	57.5	57.5	77	92.5
T	19	24	30	36	46	46	60	96	150
U	1s	1.5s	1.5s	1.5s	2s	2s	2.5s	4s	6s
V	16.5	23	23	31.5	31.5	15	15	10	50
W	85	124	124	120	120	150	150	165	267
Z	12	18	18	20	20	23	23	23	30

※Actual performance may vary by application or product. ※Refer to page 20 for the interpretation of the chart.

※Size and weight may be changed without prior notice.

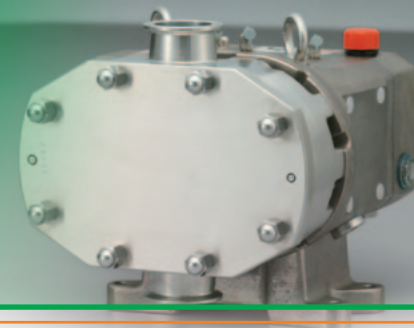

### Features and Benefits

#### Smallest Clearance

Special alloy "Nakamura Metal No.3" can make the smallest clearance between rotors and casing.

- Convey a constant volume of liquid.
- Self-priming
- Distribution of all levels of viscosity

#### Highest Degree of Cleanability

- Limited number of spaces within the pump for liquids to pool results in easy cleaning.
- Placed vertically with a CIP mechanism, this pump eliminates every last drop of liquid from the interior of the pump.
- Incredibly easy assembly /disassembly. Completely cleaned and sterilized with CIP & SIP processes. Standard: 95°C, High Temperature: 150°C

#### Maximum Discharge Pressure 1.0 MPa=10 bar

#### Special Features for SC

- Fixed Shaft Rotor . . . Disassembly / assembly is now a simple process. Because the shaft is fixed to the rotor, the rotor can be easily and accurately installed.
- Flat Head Rotor & Cover . . . The head of the rotor and the cover is flat. This dramatically minimises the spaces in which liquid pooling may occur.
- Super Clean Mechanical Seal . . . The mechanical seal is simple and compact in design. There are no O-ring grooves, which may trap liquids and this contributes to easy cleaning.
- Loosening the nut at the rear of the rotor unitized with the shaft enables easy disassembly, making it convenient for maintenance such as replacing mechanical seals.

#### Vertical and Horizontal

#### Double and Single Blade Rotors



### Specifications

Size	Connection	Flow Rate
15	1.5s	70L/min
30	2s	125L/min
60	2s	240L/min
130	3s	480L/min



### Construction Diagram

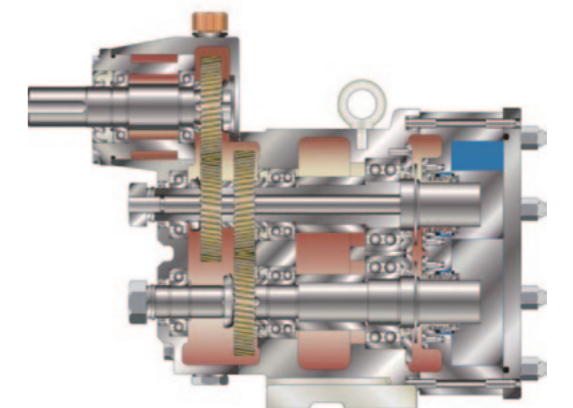

Structural Drawing p33

Codification Chart p34

Performance Curve p35

Dimensional Drawing p36





## Exploded view of components in contact with liquids

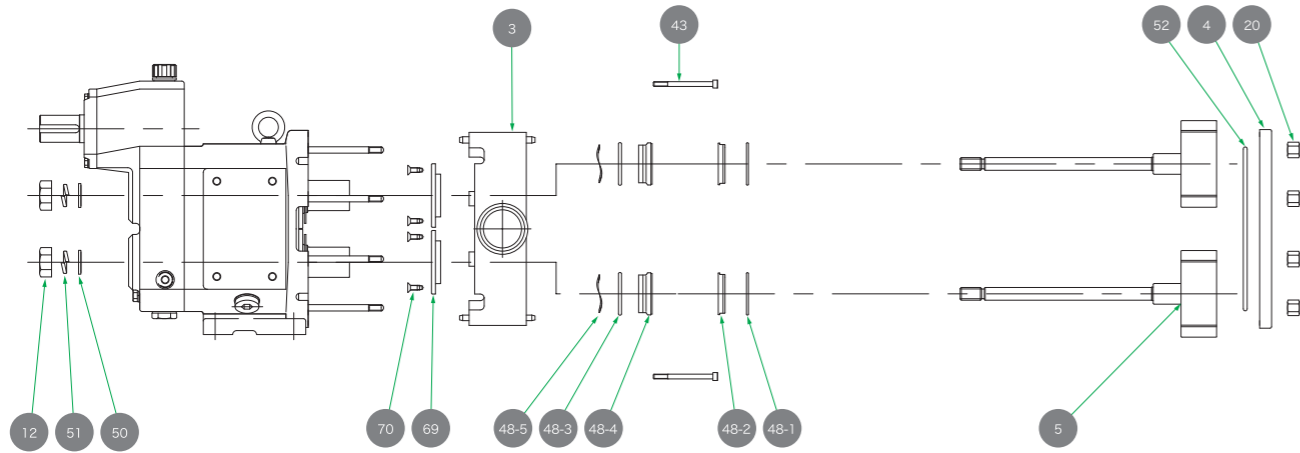

No.	Parts	No.	Parts
3	Casing	43	Cap bolt
4	Casing cover	50	Washer
5	Rotor	51	Spring washer
12	Nut	52	Cover O-ring
20	Hexagon cap nut		

## Mechanical Seal Structure

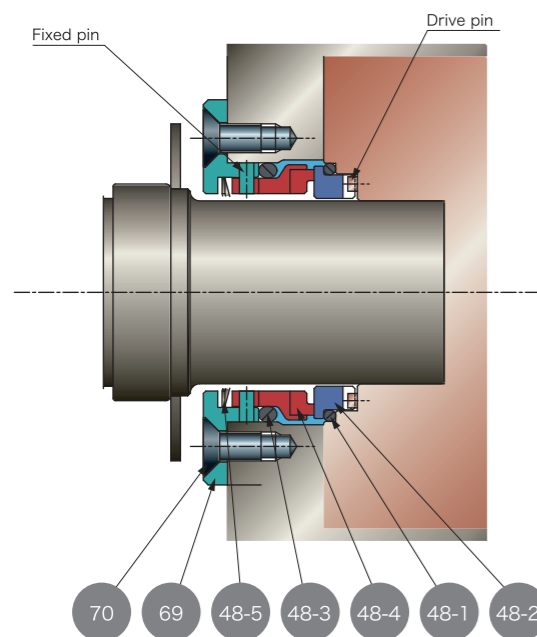

No.	Mechanical Seal
48-1	Mating ring O-ring
48-2	Mating ring
48-3	Primary ring O-ring
48-4	Primary ring
48-5	Wave spring
69	Mechanical seal retainer
70	Flathead screw for retainer

As an example

**C SC 15 T - VT - SM - Z**

① ② ③ ④ ⑤ ⑥ ⑦

- ① Kind of Option
- ② Pump Model
- ③ Pump Size
- ④ Material of Mechanical Seal
- ⑤ Material of O-ring
- ⑥ Connection
- ⑦ Installation Option

### ① Kind of Option

Mark	Contents
C	CIP JET Pump Type
D	Single Blade Rotor
F	Flushing Type
G	Jacket (Casing / Casing Cover)
HT	High Temperature Type (Max. 150°C)
K	Rectangular Port
Q	Quenching
S	Vacuum Type
V	Vertical Type
W	Tandem-Seal Type
T	Titanium Pump

### ② Pump Model

Model	Contents
SC	Super Clean Pump (Easiest Cleaning)

### ③ Pump Size

SC Series					
Size	Port	Max Speed (rpm)	Max Capacity (L/min)	Displacement (L/rev)	Max Pressure (bar)
15	1 1/2"	700	70	0.100	10
30	2"	450	125	0.277	10
60	2"	450	240	0.533	10
130	3"	450	480	1.066	10

### ④ Material of Mechanical Seal

Mark	Material
T	Tungsten Carbide & Tungsten Carbide
SS	Silicon Carbide & Silicon Carbide
SNT	Knife-Edge Silicon Carbide & Tungsten Carbide
TNT	Tungsten Carbide & Tungsten Carbide for Liquid Sugar
... Further Materials on Request	

### ⑤ Material of O-ring

Mark	Material
No Mark	NBR
VT	FKM
EP	EPDM
SI	Silicon
K	Kalrez
Y	PTFE

### ⑥ Connection

Mark	Contents
D	DIN11851
SM	SMS
DF	DIN Flange
TC	Tri-Clamp (ISO2852)
C	Clamp
F	Flange (Japanese Standard)
Z+Connection Mark	Different Port Size
... Further Connection Type on Request	

### ⑦ Installation Option

Mark	Contents
Z	Special Options (e.g.)
	- SUS316L/ Hastelloy (Wetted Materials)
	- SUS316/ SUS316L (Rotors)
	- Electrical Polish
CW	- Roughness of Surface (Ra ≤ 0.8)
	- Nickel Coating for Housing
CW	- Nickel Coating for Housing
	- Churning measure (e.g. Cream)

JM/JC  
JMU  
SC  
AMXN

# SC Performance Curve

# SC Dimensional Drawing

SC15

PORT SIZE 1.5"  
PRODUCT Water & Newtonian fluid

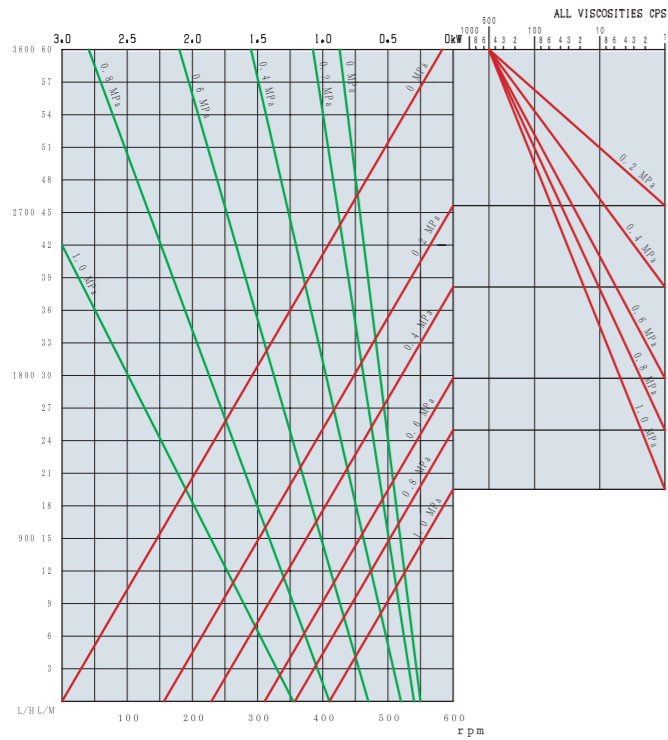

SC60

PORT SIZE 2"  
PRODUCT Water & Newtonian fluid

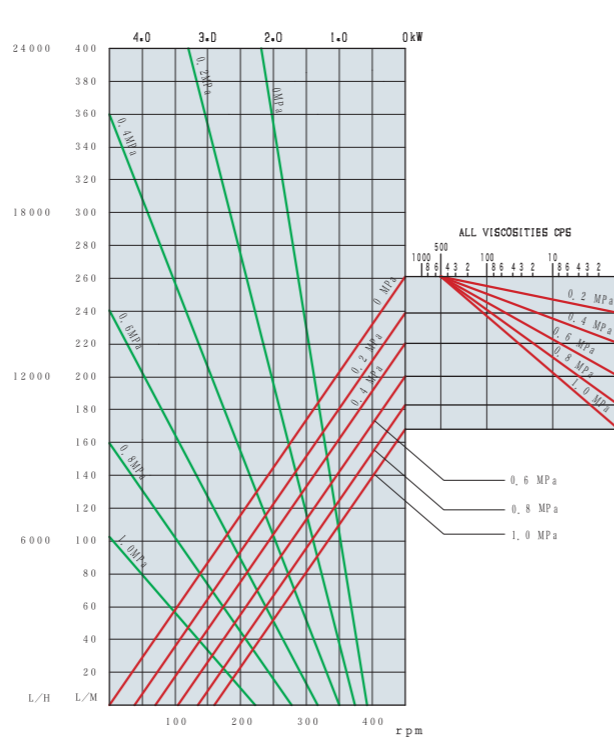

SC30

PORT SIZE 2"  
PRODUCT Water & Newtonian fluid

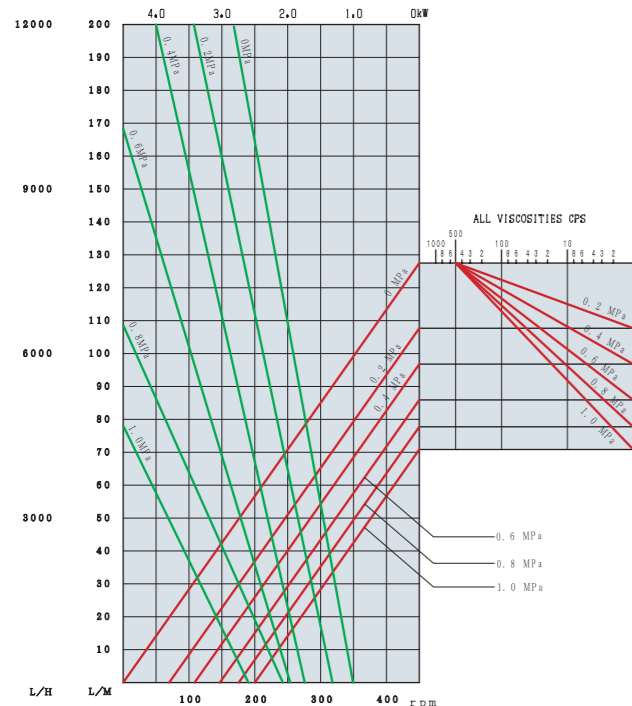

SC130

PORT SIZE 3"  
PRODUCT Water & Newtonian fluid

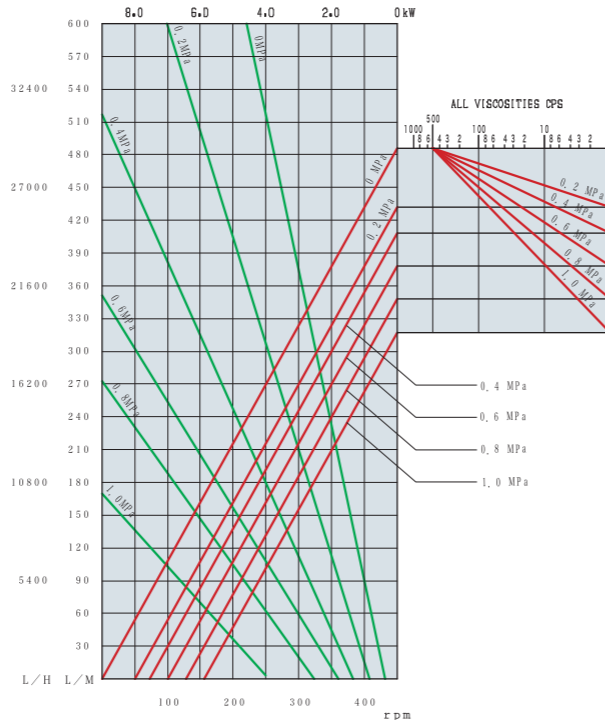

SC Series

Type Mark	SC15	SC30	SC60	SC130
A	377.5	477.5	547.5	577.5
B	324	380	470	485
C	55	56	65	65
D	50	50	60	60
E	14	15	20	20
F	80	99	115	115
G	108	129	155	155
H	49	60	80	80
I	205	259	358	358
J	22	34	45	45
K	Width 6	10	12	12
	Depth 3.5	5	5	5
L	107.5	133	185	185.5
M	276.5	340	459	459
N	180	217	270	270
O	90	108.5	135	135
P	150	174	230	230
Q	174	198	260	260
R	11	11	14	14
S	65	84	115	115
T	30	47	47	72
U	1.5s	2s	2s	3s
V	75	91	128	128
W	195	221	275	275
Z	18	20	23	23

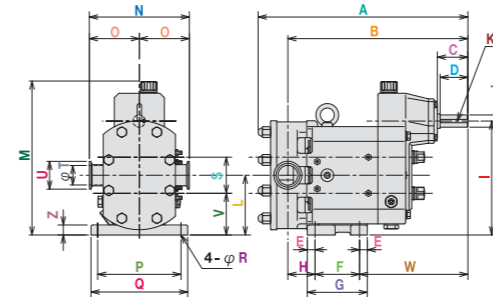

VSC Series

Type Mark	VSC15	VSC30	VSC60	VSC130
A	377.5	477.5	547.5	577.5
B	324	380	470	485
C	55	56	65	65
D	50	50	60	60
E	15	15	20	20
F	60	75	125	125
G	90	105	165	165
H	67	84	70	85
I	113	140	150	150
J	22	34	45	45
K	Width 6	10	12	12
	Depth 3.5	5	5	5
L	254.5	296	407.5	407.5
M	219.5	251.5	300	300
N	180	217	270	270
O	90	108.5	135	135
P	170	196	280	280
Q	196	220	310	310
R	11	11	14	14
S	97.5	126	172.5	172.5
T	30	47	47	72
U	1.5s	2s	2s	3s
V	23	31.5	15	15
W	197	221	275	275
Z	18	20	23	23

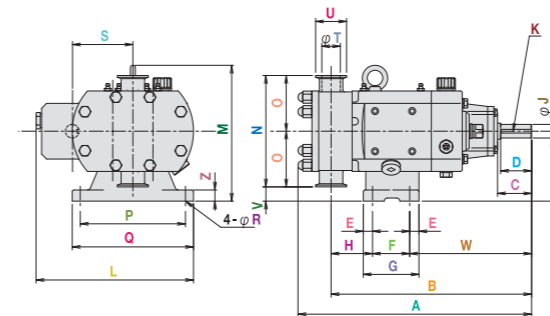

※Actual performance may vary by application or product. ※Refer to page 20 for the interpretation of the chart.

※Size and weight may be changed without prior notice.





### Features and Benefits

#### Smallest Clearance

Special alloy "Nakamura Metal No.3" can make the smallest clearance between rotors and casing.

- Convey a constant volume of liquid.
- Self-priming
- Distribution of all levels of viscosity

#### High Degree of Cleanability

Incredibly easy assembly /disassembly. Completely cleaned and sterilized with CIP & SIP processes. Standard: 95°C, High Temperature: 150°C

#### Special Features for AMXN

- The aseptic rotary pumps completely isolate the products from the atmosphere to maintain the products free from germs.
- Double layered Seal + Steam Barrier  
The seal mechanism in the pump is double-layered with a steam barrier on the interior of the two steam pathways inside the pump. This prevents any contamination of the pump interior by airborne bacteria or the like.  
Medium solution: Sterile water and steam

#### CIP JET

Halls and Channels in casing and cover allow self-cleaning without disassembly, creating a very efficient cleaning process.(P44)

**Maximum Discharge Pressure 0.7 MPa=7 bar**  
(For details see Models Condification Chart,P40)

#### Vertical and Horizontal

#### Double and Single Blade Rotors



### Specifications

Size	Connection	Flow Rate
2400	1.5s	41L/min
3400	1.5s	57L/min
7000	2s	110L/min
10000	2s	176L/min
14000	2s	270L/min
24000	3s	430L/min

Structural Drawing p39

Codification Chart p40

Performance Curve p41

Dimensional Drawing p42



# AMXN Structural Drawing

# AMXN Codification Chart

## Exploded view of components in contact with liquids

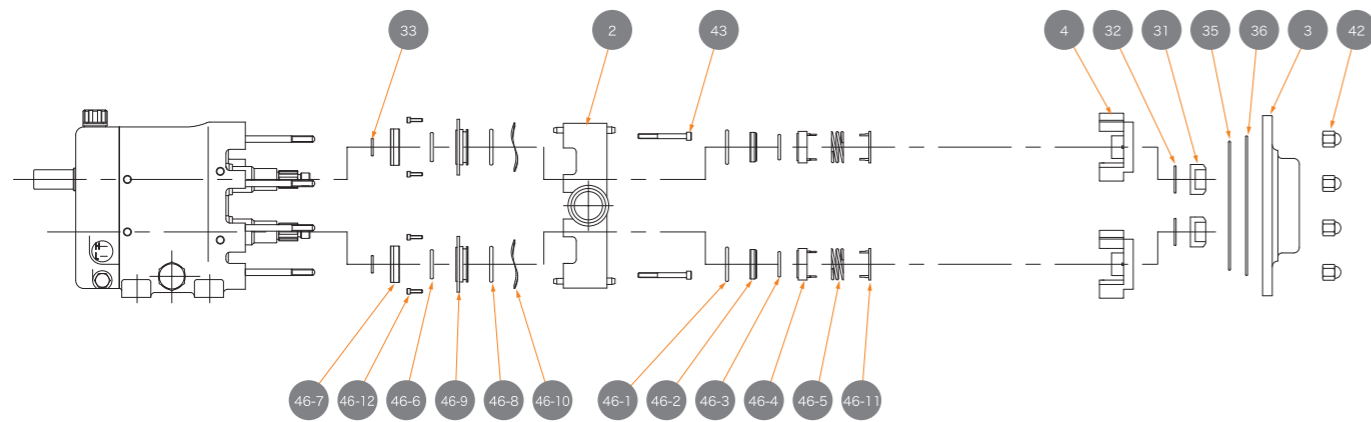

No.	Parts	No.	Parts
2	Casing	33	Rotor O-ring
3	Casing cover	35	Cover O-ring(in)
4	Rotor	36	Cover O-ring(out)
31	Cap nut	42	Hexagon cap nut
32	Nut O-ring	43	Cap bolt

## Structure in contact with liquids and structure of mechanical seal

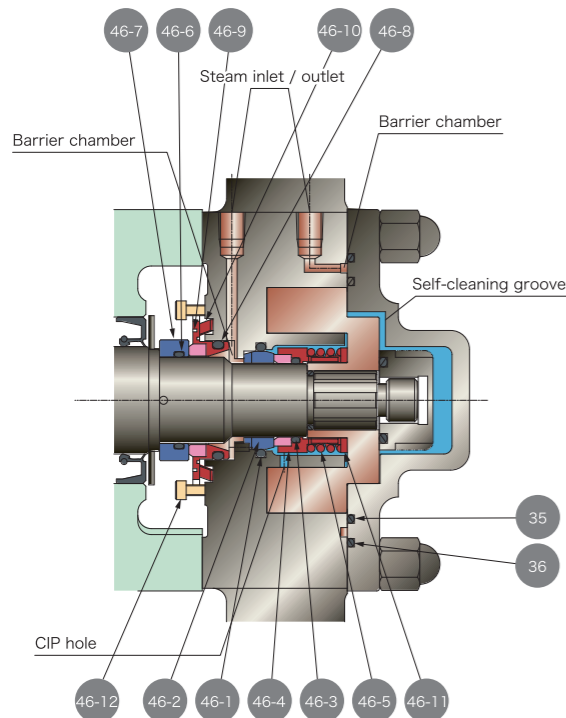

No.	Mechanical Seal Parts on Pump Side
46-1	Mating ring O-ring
46-2	Mating ring
48-3	Primary ring O-ring
46-4	Primary ring
46-5	Coil spring
46-11	Spring holder

No.	Mechanical Seal Parts on Atmospheric Side
46-6	Mating ring O-ring
46-7	Mating ring
46-8	Primary ring O-ring
46-9	Primary ring
46-10	Wave spring
46-12	Cap bolt for mechanical seal

As an example

**AV MXN 2400 T - VT - SM - Z**

① ② ③ ④ ⑤ ⑥ ⑦

- ① Kind of Option
- ② Pump Model
- ③ Pump Size
- ④ Material of Mechanical Seal
- ⑤ Material of O-ring
- ⑥ Connection
- ⑦ Installation Option

### ① Kind of Option

Mark	Contents
D	Single Blade Rotor
G	Jacket (Casing / Casing Cover)
V	Vertical Type
T	Titanium Pump

### ② Pump Model

Model	Contents
AMXN	Aseptic Pump

### ③ Pump Size

Size	Port	Max Speed (rpm)	Max Capacity (L/min)	Displacement (L/rev)	Max Pressure (bar)
2400	1 1/2"	800	40	0.050	7
3400	1 1/2"	600	60	0.100	7
7000	2"	450	99	0.220	7
10000	2"	450	189	0.420	7
14000	2"	450	279	0.620	7
24000	3"	450	450	1.000	7

### ④ Material of Mechanical Seal

Mark	Material
T	Tungsten Carbide & Tungsten Carbide
SS	Silicon Carbide & Silicon Carbide
... Further Materials on Request	

### ⑤ Material of O-ring

Mark	Material
No Mark	NBR
VT	FKM
EP	EPDM
SI	Silicon
K	Kalrez
Y	PTFE

### ⑥ Connection

Mark	Contents
D	DIN11851
SM	SMS
DF	DIN Flange
TC	Tri-Clamp (ISO2852)
C	Clamp
F	Flange (Japanese Standard)
Z+Connection Mak	Different Port Size
... Further Connection Type on Request	

### ⑦ Installation Option

Mark	Contents
Z	Special Options (e.g.)
	- SUS316L/ Hastelloy (Wetted Materials)
	- SUS316/ SUS316L (Rotors)
	- Electrical Polish
	- Roughness of Surface (Ra ≤ 0.8)
	- Umbrella Rotors (e.g. Chocolate, Paste)
CW	- Nickel Coating for Housing
	- Churning measure (e.g. Cream)



# AMXN Performance Curve

# AMXN Dimensional Drawing

**AMXN2400**

**PORT SIZE** 1.5"  
**PRODUCT** Water & Newtonian fluid

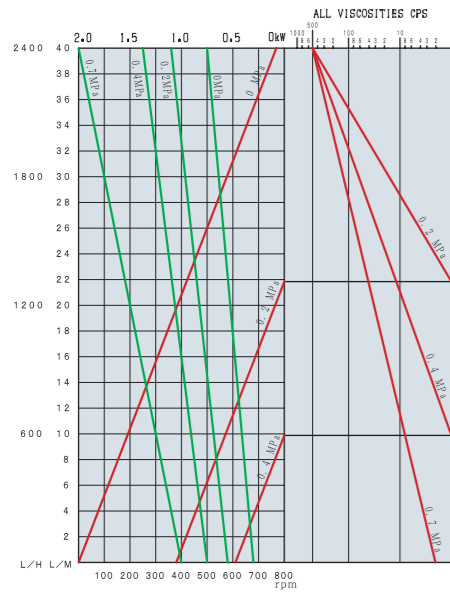

**AMXN7000**

**PORT SIZE** 2"  
**PRODUCT** Water & Newtonian fluid

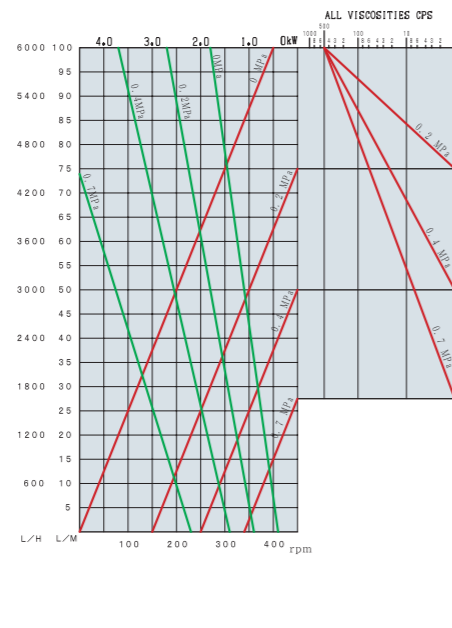

**AMXN14000**

**PORT SIZE** 2"  
**PRODUCT** Water & Newtonian fluid

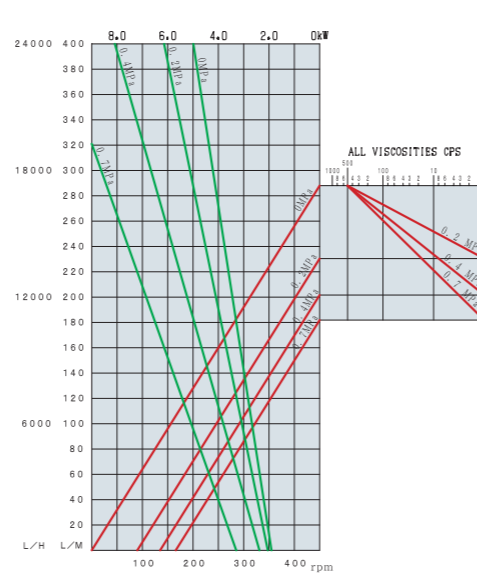

**AMXN Series**

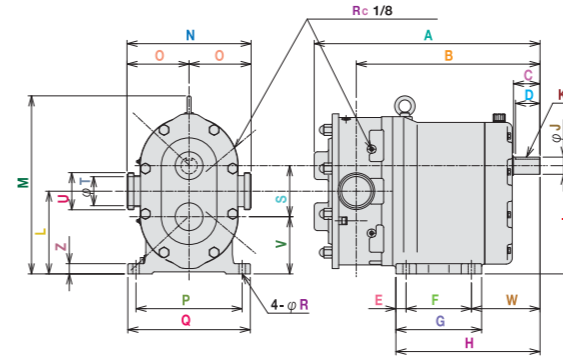

Type Mark	2400	3400	7000	10000	14000	24000
A	361.5	361.5	420	477	535	535
B	301	293	341	382	443	440
C	48	48	58	65	65	65
D	48	48	50	62	60	60
E	18	18	20	20	25	25
F	90	90	104	130	160	160
G	126	126	144	170	210	210
H	236	236	277	312	353	353
I	146	146	185	220	265	265
J	24	24	35	38	42	42
K	8	8	8	10	12	12
Width	4	4	4	5	5	5
Depth	4	4	4	5	5	5
L	113.5	113.5	140	169.7	202.5	202.5
M	225	225	323	366	436	436
N	210	210	240	260	304	304
O	105	105	120	130	152	152
P	160	160	184	210	260	260
Q	190	190	214	240	300	300
R	11	11	12	13	18	18
S	65	65	90	100.6	125	125
T	22	34	47	47	47	73
U	1.5s	1.5s	2s	2s	2s	3s
V	81	81	95	119.4	140	140
W	128	128	153	166	168	168
Z	22	22	25	25	25	25

**AMXN3400**

**PORT SIZE** 1.5"  
**PRODUCT** Water & Newtonian fluid

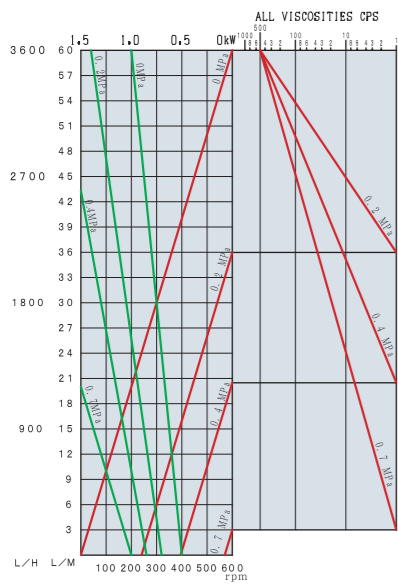

**AMXN10000**

**PORT SIZE** 2"  
**PRODUCT** Water & Newtonian fluid

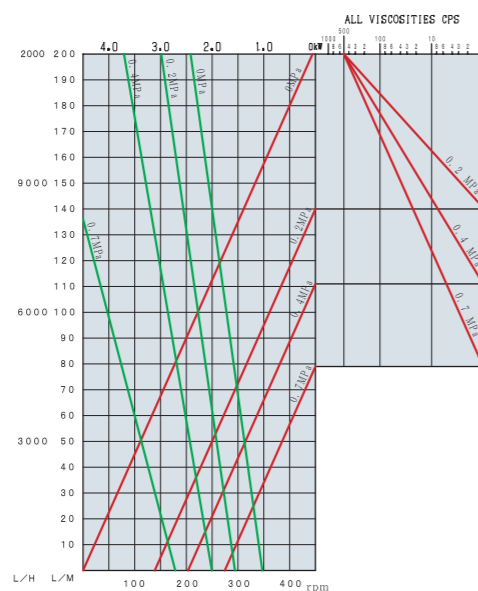

**AMXN24000**

**PORT SIZE** 3"  
**PRODUCT** Water & Newtonian fluid

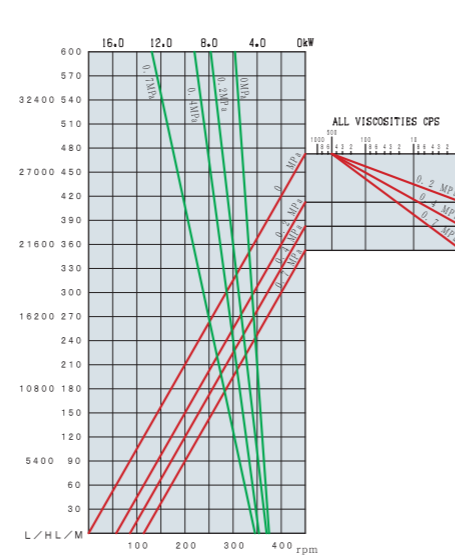

**AVMXN Series**

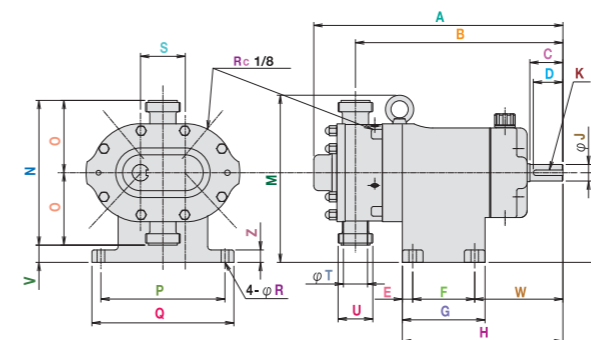

Type Mark	2400	3400	7000	10000	14000	24000
A	361.5	361.5	420	477	535	553
B	301	293	341	382	443	450
C	48	48	58	65	65	65
D	48	48	50	62	60	60
E	15	15	21	22	25	25
F	90	90	100	106	135	160
G	120	120	142	150	185	185
H	233	233	271	303	341	341
I	130	130	140	160	180	180
J	24	24	35	38	42	42
K	8	8	8	10	12	12
Width	4	4	4	5	5	5
Depth	4	4	4	5	5	5
M	243	243	278	307	351	351
N	210	210	240	260	304	304
O	105	105	120	130	152	152
P	180	180	225	220	260	260
Q	206	206	214	256	300	300
R	11	11	13	14	18	18
S	65	65	90	100.6	125	125
T	22	34	47	47	47	73
U	1.5s	1.5s	2s	2s	2s	3s
V	25	25	20	30	140	140
W	128	128	150	175	181	181
Z	18	18	25	25	25	25

※Size and weight may be changed without prior notice.

# One-step Manufacturing System

- Consult
- Manufacturing
- Quality Control
- Delivery & Support



Nakakin proposes semi custom made products that meet customers' specifications and requests. Nakakin offers not only the pump functions that best fit customers' products but also parts, materials and colors to suit customers' preferences.



Having started as a foundry, Nakakin uses casting know-how to manage consistent manufacturing from parts production to product assembly. Nakakin is proud of its, highly skilled artisans and technicians, capable of precision adjustment and assembly. This precision can not be achieved using machinery.



Nakakin products undergo as many as 100 inspection items and the tests are particular to the specifications of each pump. Only those pumps passing our stringent inspection and tests are delivered to customers. This ensures high performance and customer satisfaction.



Nakakin tailors its delivery and shipping to meet individual customer requirement. Nakakin offers a complete support system, supplying customer with consumable parts, maintenance and troubleshooting.

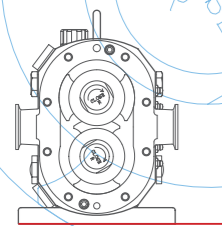

## Operating Principle

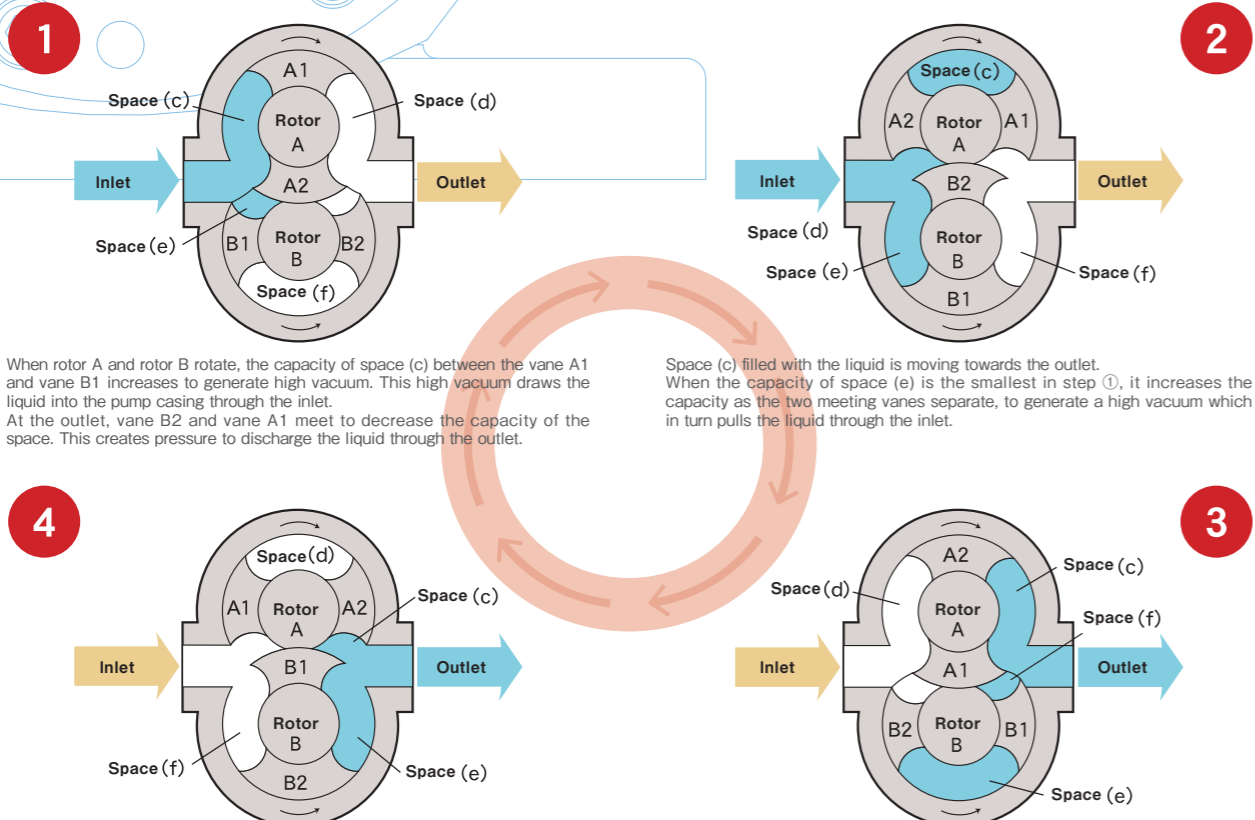

When rotor A and rotor B rotate, the capacity of space (c) between the vane A1 and vane B1 increases to generate high vacuum. This high vacuum draws the liquid into the pump casing through the inlet. At the outlet, vane B2 and vane A1 meet to decrease the capacity of the space. This creates pressure to discharge the liquid through the outlet.

Space (c) filled with the liquid is moving towards the outlet. When the capacity of space (e) is the smallest in step ①, it increases the capacity as the two meeting vanes separate, to generate a high vacuum which in turn pulls the liquid through the inlet.

With the two rotors in this position, the capacity of space (c) becomes the smallest. The pump returns to step ① to repeat the pumping cycle again.

When vane B1 and vane A2 meet, the capacity of space (c) decreases to generate pressure. This causes the liquid to be pumped out through the outlet. The capacity of space (d) increases when the two rotors rotate to separate the two vanes. This creates a vacuum to pull the liquid in.

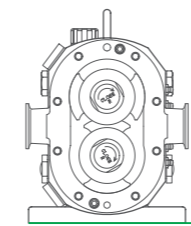

# CIP JET Function

## What is CIP JET function?

- The CIP JET function improves cleanliness inside the pump (portions in contact with liquid) during the clean-in-place (CIP) process. A sufficient amount of cleaning agent reaches inside the pump casing shafts, which are the most difficult parts to wash. This is why the CIP JET function alone cleans inside the pump without disassembling.
- Prevents liquid from changing its characteristics caused by liquid buildup. The inside profile of the pump casing shafts (portions in contact with a liquid) is designed to avoid liquid buildup. This reduces liquid degradation.

## Operating Principles

The CIP JET function uses a pressure difference that exists between the inlet and outlet of the pump. Pumps with the CIP JET function have four "CIP JET holes and slits".

### Operating sequence of CIP JET flow

- The rotors of a pump equipped with the CIP JET function turn.
  - A pressure difference is generated between the inlet (low pressure area) and the outlet (high pressure area).
  - The liquid is pushed back from the high pressure area (outlet) to the low pressure area (inlet) through the CIP JET holes and slits.
  - The suction motion of the pump generates a force that extracts the liquid at the low pressure area.
- Repeating steps (1) to (4), continues high pressure liquid flow.

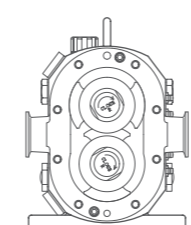
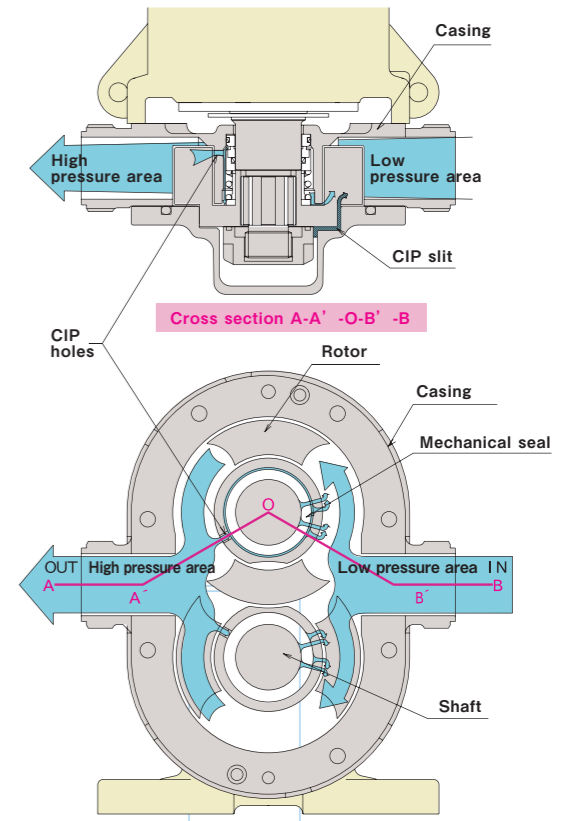

# Vented Cover Function

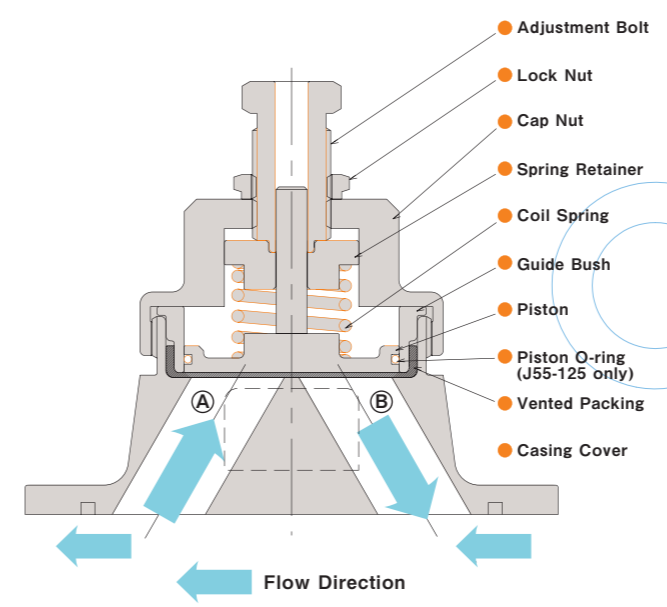

## Advantages

The automatic pressure regulation protects the pump from failure and mechanical problems.

## Operating Principles

The "spring" and "piston" of the vented packing normally send pressure towards the portions of the pump that are in contact with the liquid. When the pressure inside the pump (or portions in contact with the liquid) becomes higher than the pressure exerted by the spring, the pressure difference pushes the vented packing up in the opposite direction from the portions in contact with the liquid. This causes the liquid to reverse its flow through bypasses A and B, suppressing the pressure increase inside the pump (portions in contact with the liquid).





# Company Profile

## Overview

Company Name NAKAKIN CO., LTD  
 President Takuji Ehomoto  
 Established March 1964 (Founded in 1950)

Capital 84 million yen  
 Employees 450

## History

- Sept.1950 Nakamura Metals & Casting Co. was founded by Shigezo Nakamura, the father of Mitsuo Nakamura, the chairman. There were then two departments: pattern and metal mold making, and aluminum and copper alloy casting.
- Nov.1970 The Metal Mold Division was moved to its newly built premises, Torikai Plant (Metal Mold Division)at Higashihitotsuya in Settsu City, Osaka Prefecture.
- Dec.1972 The business of Nakamura Metal Co., Ltd. was merged with the Yodogawa plant (Valve Division) of the Nakamura Metallic Industry Co., Ltd. and renamed.
- April1973 Rotary piston pumps were manufactured and sold at the Hirakata Plant for the first time under our own brand name. The Industrial Precision Machinery Division (Pump Division) was established.
- May1982 The Tokyo pump Office (Industrial Precision Machinery Division) was opened.
- Sept.1986 Nakamura Seiko was established in Nangoku City, Kochi Prefecture.
- May1989 The Head Office Building was constructed in Yodogawa-ku, Osaka City.
- April1992 The new Kasuga Plant was constructed in Kasuga-kitamachi, Hirakata City.
- April1993 The company name was revised to Nakakin Co., Ltd.
- May1995 Our overseas affiliated company, P.T.Nakakin Indonesia was established in Jakarta, Republic of Indonesia, as the first overseas production base. Its capital was 100% provided by Nakakin Co., Ltd.
- Nov.2002 Hirakata Plant and Kasuga Plant received ISO9001 certification.
- March2005 Head Office and Hirakata Plant and Kasuga Plant received ISO14001 certification.
- Jan.2012 The Europe office was opened in Germany.

## Map

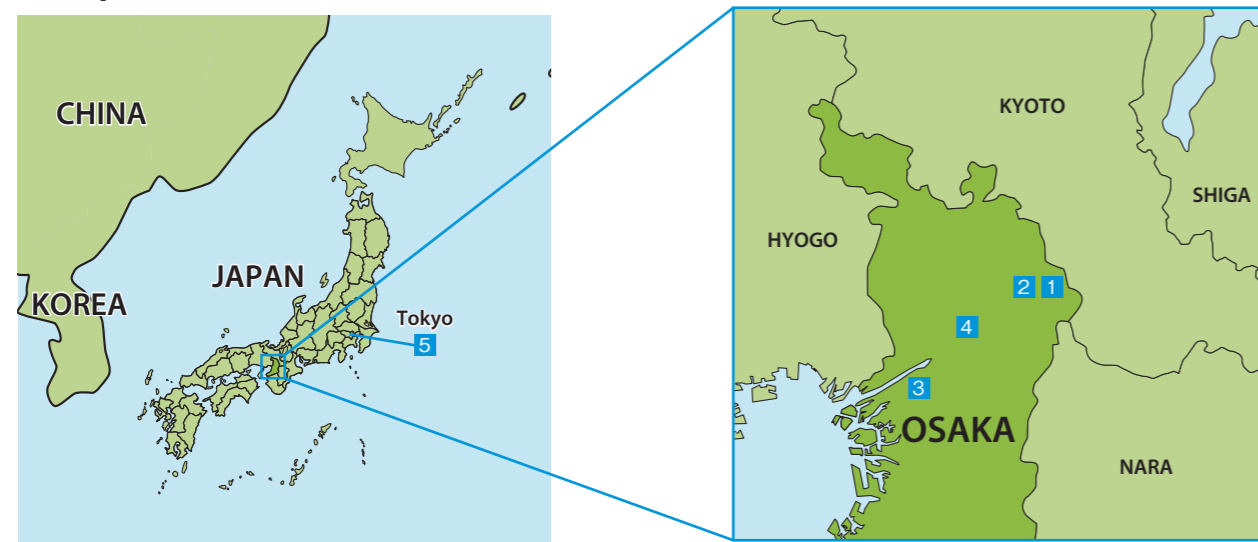

1 Hirakata Plant 2 Kasuga Plant 3 Head Office 4 Torikai Plant 5 Tokyo Office 6 Europe Office

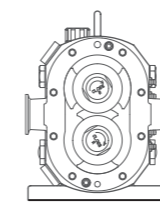

# Technical Information

## Performance

- Flow rate up to 90,000 l/h
- Screw-type mounting foot for horizontal and vertical installation
- Flow Direction: Left↔Right : Up↔Down

## Product Viscosity

- Up to 300,000 mPas

## Colors

- Munsell 7.5 GY 9/2
- RAL-lacquer coatings on request

## Materials

- Pump housing and cover: stainless steel (1.4571/AISI 316)
- Double blade rotors : Patented alloy

## Design

- Easy stock-keeping and spares inventory due to standardized sizes
- Operation pressure up to 15 bar
- Suction head up to 9 mWS

## Connections

- Male parts (DN), DIN 11851 (Standard)
- SMS
- Aseptic flanges DIN 11864-2
- Aseptic Screwed Connection DIN 11864-1
- Tri-clamp, ISO 2852
- Further connection types on request

## Mechanical Shaft Seal

- Carbon/Ceramics
- Tungsten Carbide
- Silicon Carbide
- Further materials on request

## Sealing Material of O-Rings

- Viton
- EPDM
- Further materials on request

## Temperature Resistance

- Up to 95°C (Standard Model)
- Optional up to 150°C (High Temperature Model)

## JM • JO • JMU Series

Sizes	4	10	16	25	40	55	125	160	200	300
Max. rpm[ $\text{min}^{-1}$ ]	800	800	600	450	450	450	450	450	450	450
Max. Pressure[bar]	7	15	15	15	15	15	15	15	15	15
HP*1 Max. Pressure[bar]	-	15	15	15	15	15	15	15	15	15
Size of Connection [Inch/DN]	1/25	1.5/40	1.5/40	1.5/40	2/50	2/50	2.5/65	4/100	4/100	6/150
Max Feeding Capacity*2 [liter/minute]	20	40	60	100	135	270	410	710	930	1470
Max Feeding Capacity*2 [liter/hour]	1200	2400	3600	6000	8100	16200	24600	42600	55800	88200

※1: HP = High Pressure Version ※2:Based on water without counter pressure,i.e. approx. 1 mPas/0 bar

JM JO JMU

## SC Series

Sizes	15	30	60	130
Max. rpm[ $\text{min}^{-1}$ ]	700	450	450	450
Max. Pressure[bar]	10	10	10	10
Size of Connection [Inch/DN]	1.5/40	2/50	2/50	3/6.5
Max Feeding Capacity*2 [liter/minute]	70	125	240	480
Max Feeding Capacity*2 [liter/hour]	4200	7500	14400	28800

※2:Based on water without counter pressure,i.e. approx. 1 mPas/0 bar

## AMXN Series

Sizes	2400	3400	7000	10000	14000	24000
Max. rpm[ $\text{min}^{-1}$ ]	800	600	450	450	450	450
Max. Pressure[bar]	7	7	7	7	7	7
Size of Connection [Inch/DN]	1.5/40	1.5/40	2/50	2/50	2/50	3/65
Max Feeding Capacity*2 [liter/minute]	41	57	110	176	270	430
Max Feeding Capacity*2 [liter/hour]	2460	3420	6600	10560	16200	25800

※2:Based on water without counter pressure,i.e. approx. 1 mPas/0 bar

JM/JO

JMU

SC

AMXN