

# DEPA®

brands you trust.



DEPA DH®  
Next Generation Air Operated  
Double Diaphragm Pumps

CRANE®

[www.depapumps.com](http://www.depapumps.com)  
[www.cranecpe.com](http://www.cranecpe.com)

## Features and Benefits

DEPA DH® Next Generation Air Operated Double Diaphragm Pump Series DH15, DH25, DH40, DH50 and DH80 are made of cast aluminum developed for industrial applications.

### Flexible Multiport-Connections

- A customized manifold design that improves ball valve guidance, increases functionality and provides up to 25 different installation options
- Error free assembling in combination with single-center block
- Multi-porting provides many options for installation e.g.:
  - Vertical orientation can be easily used for emptying of drums
  - No additional adapters are necessary

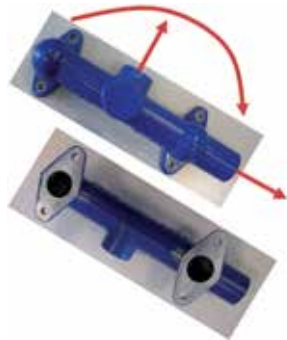

### Innovative Flange-Design

- "Block-mounted" pump and air chambers provide a safe and well-defined diaphragm clamping mechanism. The diaphragm is fixed to its specifications to provide consistent lifetime wear and tear and eliminate overstretching of the pump
- Outer rim of diaphragm is held like an O-ring with exactly defined position and deformation, due to block bolted pump chamber
- Improved leakage tightness, through consistent diaphragm fixture
- No alignment needed for pump chamber and center block



### Maintenance In Place (MIP)

- Cast feet integrated in the center block housing enable maintenance in place that can reduce downtime by up to 25%\*, decrease the number of required parts by 30%\* and eliminate the need to remove the pump for maintenance
- Optimized for error-free dis- and reassembling, also for built-in situation
- Rubber feet can easily be mounted due to slotted locating hole in the center block housing



### High Efficiency

- Flow design with Free-Flow-Path technology can accommodate particle sizes up to 25mm (DH80), increase the scope of applications and reduce the total cost of ownership through enhanced efficiency of up to 37%\*
- Reduced dead volume as the shape of the chamber has been optimized for the diaphragm design and dimensions
- Additionally available with DEPA® AirSave System with low starting pressure
- Have been optimized for low noise emissions and high leakage tightness in industrial applications

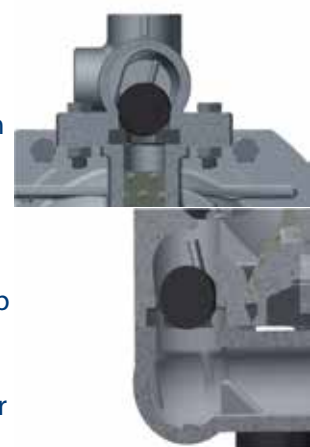

\*Compared to the previous model as determined by internal testing

## Features and Benefits

### Applications

The aluminum housing material with universally selectable interior allows versatile application possibilities. For instance in

- Painting- and coating industries
- Printing- and gluing machines
- Mechanical engineering and construction
- Automotive

### Sizes

DEPA DH® Next Generation Air Operated Double Diaphragm Pumps of aluminium series are available in nominal sizes of ½" (DN15), 1" (DN25), 1 ½" (DN40) 2" (DN50), and 3" (DN80). Equipped with DEPA® AirSave System or internal air-valve.

	Size				
	15	25	40	50	80
Suction height (m), dry <sup>1)3)</sup>	2,5	6,0	6,0	6,0	6,0
Max. solid size (mm)	6	10	15	18	25
Weight (kg)	2.0	8.2	12.0	35,4	72
Min. start-up pressure (bar) <sup>2)</sup>	0,5	0,5	0,5	1,5	1,5

1) At 2 bar air pressure (DH15/25), 7 bar (DH40)

2) AirSave System (M-valve)

3) For valve seat/valve ball combination of PTFE or stainless steel the suction height will be reduced

### Marking and Identification

The pumps are provided with a nameplate which the pump code, serial number, date of manufacturing, max. allowed temperature and pressure.

The DEPA® pump coding gives all information about size, material and equipment which allows accurate for linkage to spare parts.

### Temperature

Operation temperature of aluminum material -10°C to +130°C. Further limitations are according to interior of pump, see table with product wetted interior

Product wetted interior	Max. Temperature (°C)
NBR	-15 bis +90
EPDM	-25 bis +90
NRS	-15 bis +70
FKM	-5 bis +120
DEPA nopped S <sup>4</sup> ®	-20 bis +110
PTFE	-20 bis +100
DEPA nopped E <sup>4</sup> ®	-10 bis +130

### Applied Guidelines

- ATEX compliant in accordance with directive 94/9/ EC equipment group II, category 2GD, Explosion group IIB Tx (II 2 GD IIB Tx)
- Machinery Directive 2006/42/EC



ATEX-compliant II 2GD IIB Tx



## Pump Sizes and Equipment

**DH 25 - FA B S E T**

Connecting Dimension DN (mm) / inch	Housing Material
15 / ½"	Aluminium
25 / 1"	Aluminium
40 / 1 ½"	Aluminium
50 / 2"	Aluminium
80 / 3"	Aluminium

Material Options			
Material	Diaphragm	Valve Seat	Valve Ball
NBR	N	N	N <sup>1)</sup>
EPDM	E	E	E <sup>1)</sup>
NRS	B	B	B <sup>1)</sup>
FKM	F	F	-
DEPA nopped S <sup>®</sup>	S	-	-
PTFE	T	T	T
DEPA nopped E <sup>®</sup>	Z	-	-
Stainless Steel	-	R	R
NBR with core	-	-	Y <sup>1)</sup>
NRS with core	-	-	V <sup>1)</sup>

1) Not for size 15

Further material options are available upon request

Product Ports / Orientation of Manifolds						
		Discharge Port				
		D1	D2	D3	D4	D5
		(outlet to the top)	(outlet at opposite side of air inlet)	(outlet right hand side / view to air inlet)	(outlet at same side as air inlet)	(outlet left hand side / view to air inlet)
Suction Port	S1 (inlet from bottom)	A	B	C	O <sup>1)</sup>	P
	S2 (inlet aligned with air inlet)	D	-	E	Q <sup>1)</sup>	R
	S3 (inlet right hand side / view to air inlet)	F	G	H	T <sup>1)</sup>	U
	S4 (inlet at opposite side of air inlet)	I	J	K	W <sup>1)</sup>	X
	S5 (inlet left hand side / view to air inlet)	L	M	N	Y <sup>1)</sup>	Z

1) Not valid for DH15 with AirSave System

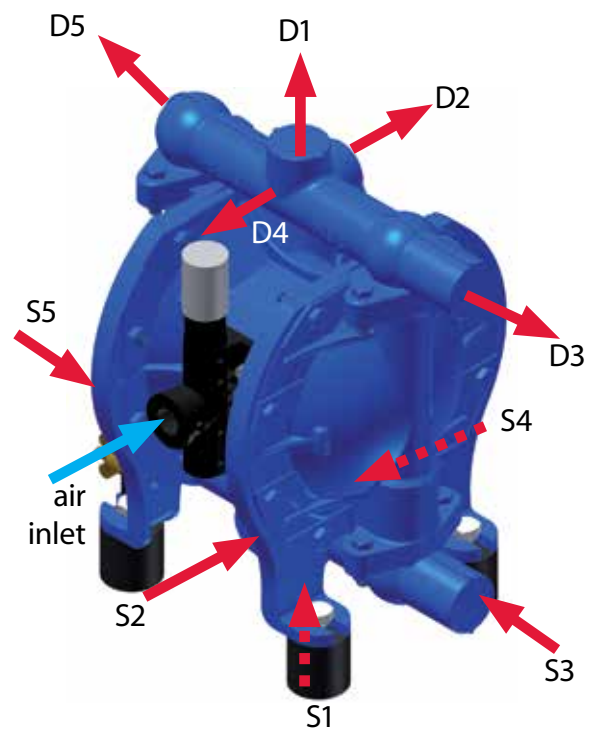

D = Discharge Side  
S = Suction Side

## Dimensions

Dimensions (mm)	Size				
	15	25	40	50	80
A	136	165	182	243	296
B	207	272	370	502	568
C	180	241	307	414	522
D	266	340	437	522	717
E	52	61	80	88	105
F	34	38	50	70	90
G	99	116	116	120	120
H	116	154	206	275	340
I	89	122	155	296	367
K	174 (186) <sup>1)</sup>	234	266	351	434
L	18	23	30	18	15
M	105	134	165	226	280
Air inlet M-Valve (inch) <sup>2)</sup>	G 1/2"		G 3/4"		

1) External DEPA® AirSave System

2) Internal airvalve G3/8"

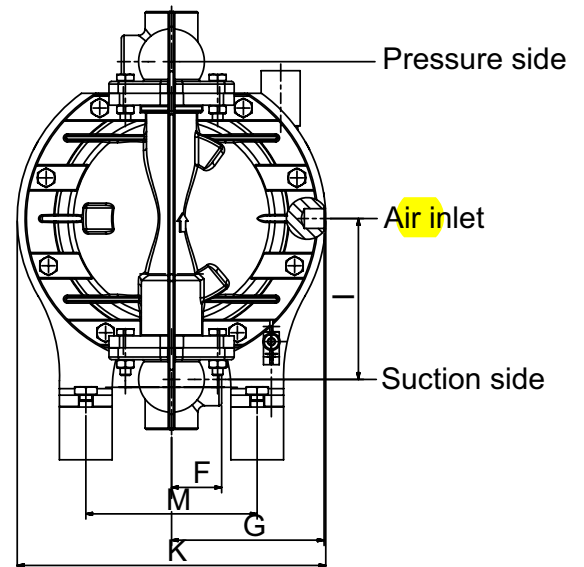
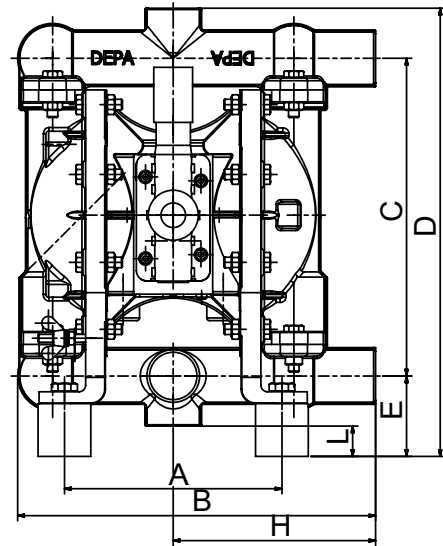

## Exploded view

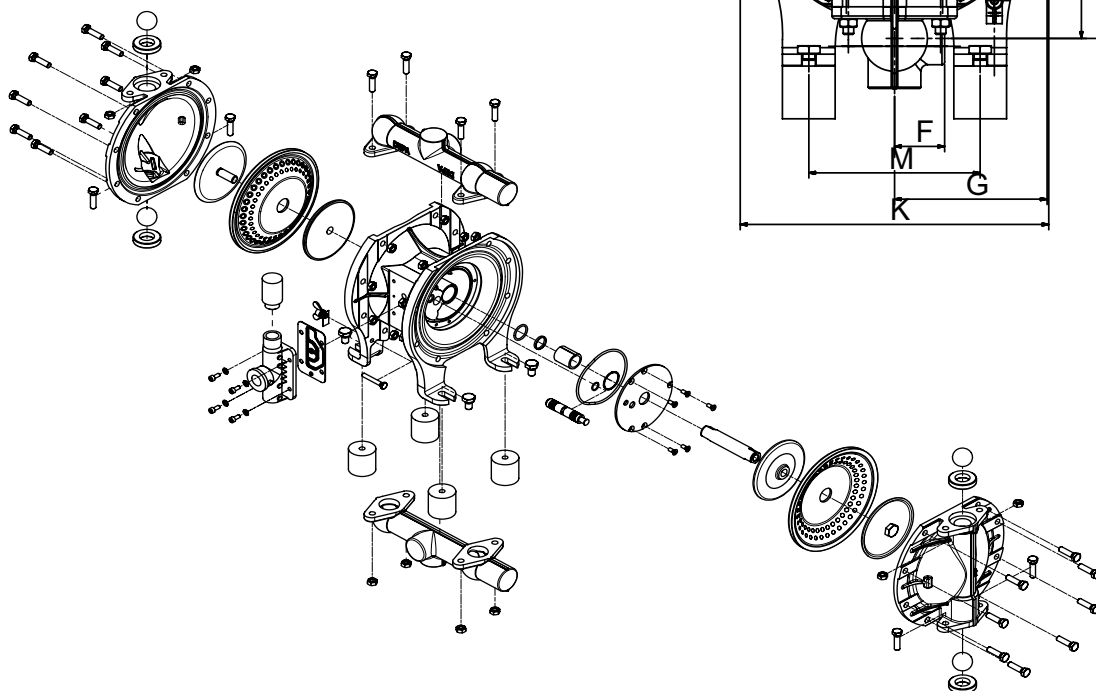

## Performance Curves

### Example for pump selection

Required is 2 m<sup>3</sup>/h as the flow rate at a discharge pressure of 4 bar. Recommend is the DL 25 for this application. The needed air supply pressure is 4,3 bar. This equals an air consumption rate of 13 m<sup>3</sup>/h.

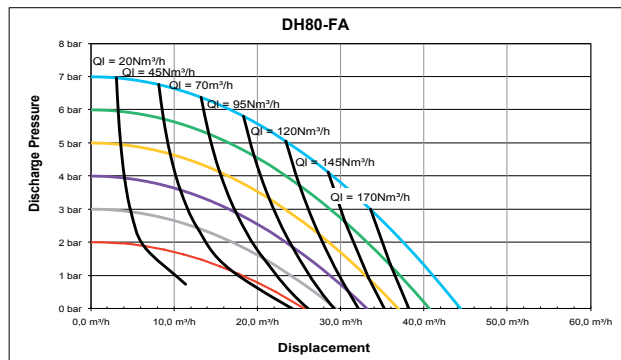
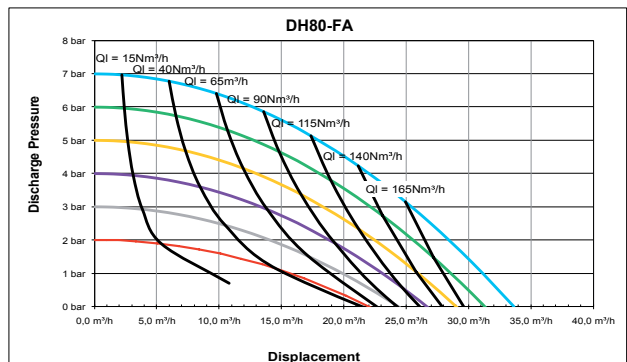
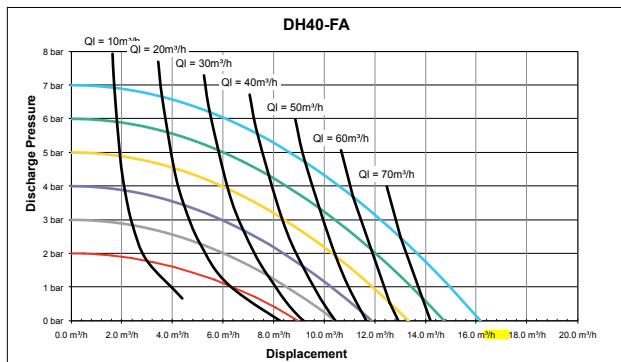
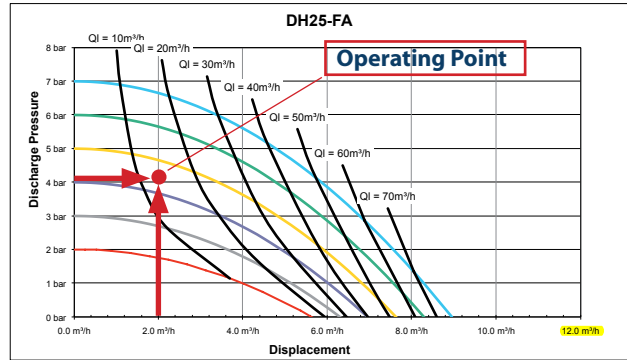
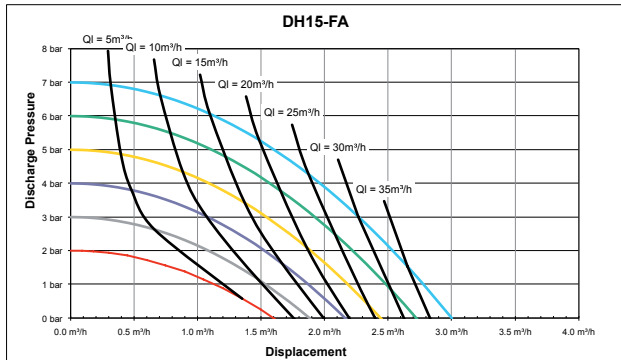

Curves are based on internal Air Valve only

## Available Accessories

### DEPA® AirSave System



Innovative and robust design: Increases energy efficiency and service life of the pump. The DEPA® AirSave System delivers outstanding performance, operating at a low start-up pressure with virtually no leakage.

The economic operation of the pump: Provides ease of maintenance, low cost operation, reduces maintenance downtime and spare parts inventory, and increases plant capacity.

Available for use in a broad range of applications: In all DEPA® pumps sizes (DH15/25/40 and DEPA Series P, Non-Metallic), for ATEX compliant applications, the air valve is also available

### Diaphragm leakage monitoring system



In case a diaphragm failure occurs, the pumped medium enters the air chamber and triggers the sensor. The sensor sends subsequently an electrical output to the monitoring device for evaluation of the signal. The control unit switches of the air supply to the air valve and thus halting the operation of the pump.

Two sensors per pump (one per chamber) are installed.

Two types of sensors are available:

- Conductivity Measurement, Standard (orange) for conductive products
- Capacity System, ATEX (blue) for non-conductive products and approved for ATEX-certified pumps.

Please note, that both types of sensors are only available from pump size 25 upward.

### Stroke Counter



The stroke counter sensor counts each cycle of the diaphragm movement. Multiplying the number of cycles with the pump chamber volumes, the discharge flow rate can be determined. For dosing applications, the stroke counter provides for precise measurement and accurate regulation.

The stroke counter sensor is located within the center block and provides an electrical output each time the diaphragm is in the end position.

The stroke counter consists of a sensor and an electronic amplifier/regulator. the sensor can be used in ATEX certified pumps.

# DEPA®

Crane ChemPharma & Energy

Crane Process Flow Technologies GmbH

Postfach 11 12 40, D-40512 Düsseldorf

Heerdter Lohweg 63-71, D-40549 Düsseldorf

Tel.: +49 211 5956-0

Fax.: +49 211 5956-111

[www.cranecpe.com](http://www.cranecpe.com)

[www.depapumps.com](http://www.depapumps.com)

**CRANE®**



**brands you trust.**



Crane Co., and its subsidiaries cannot accept responsibility for possible errors in catalogues, brochures, other printed materials, and website information. Crane Co. reserves the right to alter its products without notice, including products already on order provided that such alteration can be made without changes being necessary in specifications already agreed. All trademarks in this material are property of the Crane Co. or its subsidiaries. The Crane and Crane brands logotype, in alphabetical order, (ALOYCO®, CENTER LINE®, COMPAC-NOZ®, CRANE®, DEPA®, DUO-CHEK®, ELRO®, FLOWSEAL®, JENKINS®, KROMBACH®, NOZ-CHEK®, PACIFIC VALVES®, RESISTOFLEX®, REVO®, SAUNDERS®, STOCKHAM®, TRIANGLE®, UNI-CHEK®, WTA®, and XOMOX®) are registered trademarks of Crane Co. All rights reserved.